

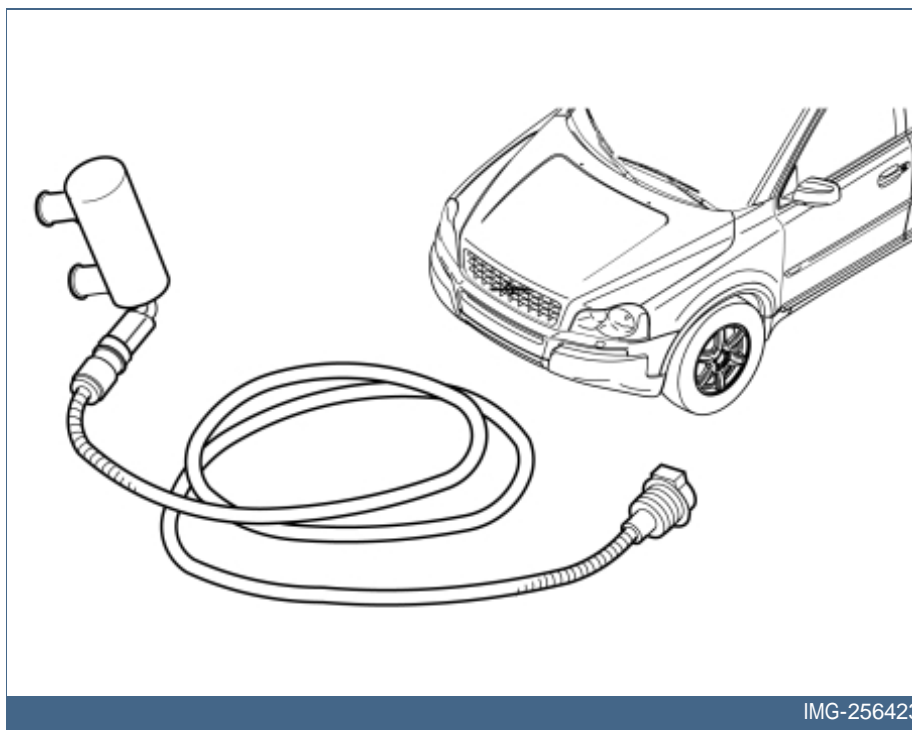

S60 / V70 (00-08) / S80 (-06) / V70 XC (01-) / XC70 (-07) / XC90

Section	Group	Weight (Kg/Pounds)	Year	Month
8	876	2/4.4	2006	09

S60 2001 D5244T, S60 2002 D5244T, S60 2002 D5244T2, S60 2003 D5244T, S60 2003 D5244T2, S60 2004 D5244T, S60 2004 D5244T2, S60 2004 D5244T3, S60 2005 D5244T, S60 2005 D5244T2, S60 2005 D5244T3, S60 2006 D5244T, S60 2006 D5244T2, S60 2006 D5244T4, S60 2006 D5244T5, S60 2006 D5244T6, S60 2006 D5244T7, S60 2007 D5244T4, S60 2007 D5244T5, S60 2007 D5244T6, S60 2007 D5244T7, S60 2008 D5244T4, S60 2008 D5244T5, S60 2008 D5244T7, S60 2009 D5244T4, S60 2009 D5244T5, S60 2009 D5244T7, S80 (-06) 2001 D5244T, S80 (-06) 2002 D5244T, S80 (-06) 2002 D5244T2, S80 (-06) 2003 D5244T, S80 (-06) 2003 D5244T2, S80 (-06) 2004 D5244T, S80 (-06) 2004 D5244T2, S80 (-06) 2005 D5244T, S80 (-06) 2005 D5244T2, S80 (-06) 2006 D5244T, S80 (-06) 2006 D5244T2, V70 (00-08) 2001 D5244T, V70 (00-08) 2002 D5244T, V70 (00-08) 2002 D5244T2, V70 (00-08) 2003 D5244T, V70 (00-08) 2003 D5244T2, V70 (00-08) 2004 D5244T, V70 (00-08) 2004 D5244T2, V70 (00-08) 2004 D5244T3, V70 (00-08) 2005 D5244T, V70 (00-08) 2005 D5244T2, V70 (00-08) 2005 D5244T3, V70 (00-08) 2006 D5244T, V70 (00-08) 2006 D5244T2, V70 (00-08) 2006 D5244T4, V70 (00-08) 2006 D5244T5, V70 (00-08) 2006 D5244T6, V70 (00-08) 2006 D5244T7, V70 (00-08) 2007 D5244T4, V70 (00-08) 2007 D5244T5, V70 (00-08) 2007 D5244T6, V70 (00-08) 2007 D5244T7, V70 (00-08) 2008 D5244T4, V70 (00-08) 2008 D5244T5, V70 (00-08) 2008 D5244T7, V70 XC (01-) / XC70 (-07) 2003 D5244T, V70 XC (01-) / XC70 (-07) 2004 D5244T, V70 XC (01-) / XC70 (-07) 2005 D5244T, V70 XC (01-) / XC70 (-07) 2006 D5244T, V70 XC (01-) / XC70 (-07) 2006 D5244T4, V70 XC (01-) / XC70 (-07) 2006 D5244T5, V70 XC (01-) / XC70 (-07) 2006 D5244T6, V70 XC (01-) / XC70 (-07) 2006 D5244T7, V70 XC (01-) / XC70 (-07) 2007 D5244T4, XC90 2003 D5244T, XC90 2004 D5244T, XC90 2005 D5244T, XC90 2006 D5244T, XC90 2006 D5244T4, XC90 2007 D5244T4, XC90 2008 D5244T4, XC90 2008 D5244T5, XC90 2009 D5244T4, XC90 2009 D5244T5



IMG-256423

Installation instructions, accessories - Electric engine block heater

Volvo Car Corporation Göteborg, Sweden



Required tools



A0000162



A0000163



Nm
lbf.ft
IMG-239664



IMG-239942

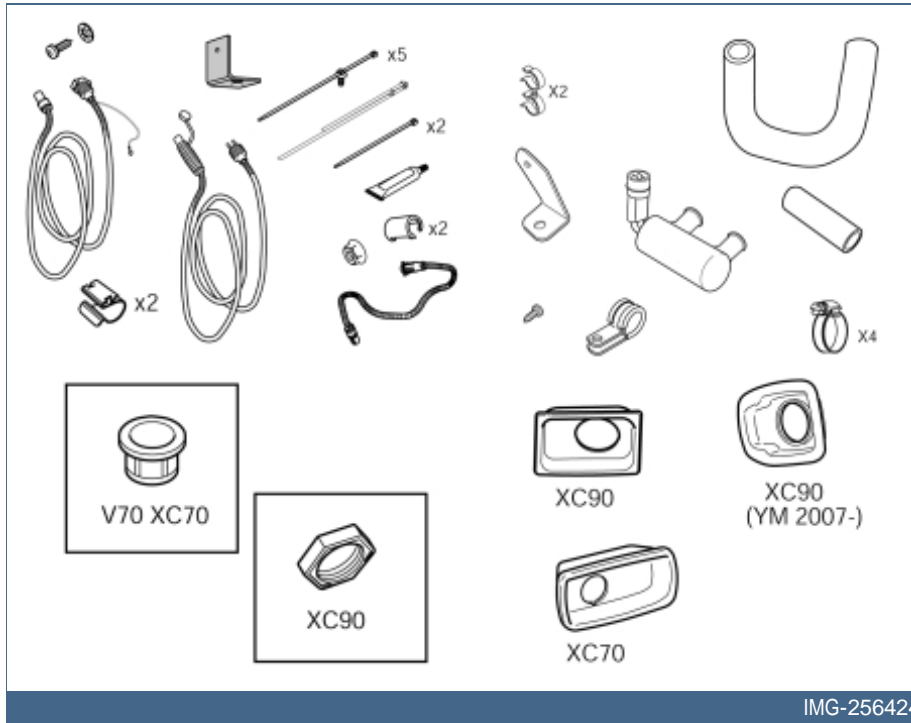

Any comments on this publication? Please contact your nearest retailer. Thank You!

Publ.no:	Issue:	Kit no:
Comments:.....		
.....		
.....		
.....		

From:	
Address:	
Telephone:	
Telefax:	

IMG-213320





INTRODUCTION

Electric engine block heater

- **NOTE! Read through the entire text before carrying out any work.**
- The front page gives the date of this edition and the edition it replaces
- The second page shows the tools needed for the installation and the contents of the installation kit
- The illustrations display the procedure in order of operation. The order of operation is repeated in the text section
- Cut out the text page in order to follow the illustrations and text at the same time.



1

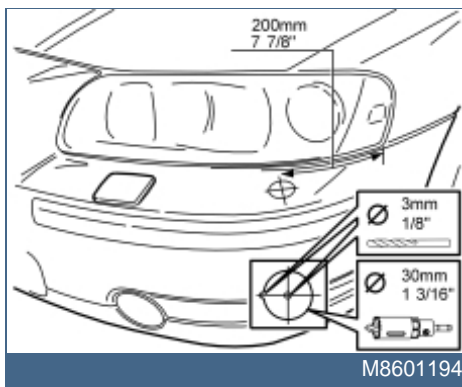

Applies to the V70 Preparations

- Measure out the hole for the front socket as illustrated. The measurement between the centre of the hole and the corner of the headlamp must be **200 mm (7 7/8")**. Measure out the hole's centre so that it is symmetrically located on the top of the bumper.
- Pre-drill the hole using a **Ø3 mm (1/8")** bit.
- Drill out the hole. Use a **Ø30 mm (1 3/16")** diameter hole saw.
- Remove any swarf.

2

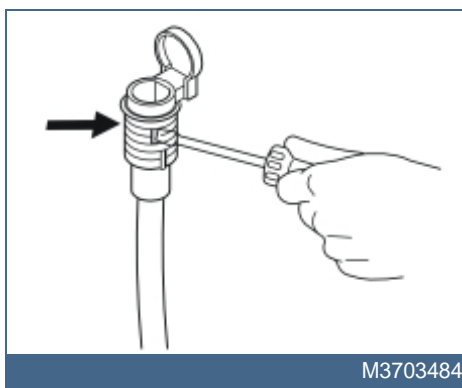

Applies to the V70

- Open the drainage holes on both sides of the connector. Use a screwdriver and press with manual force in the markings.

3

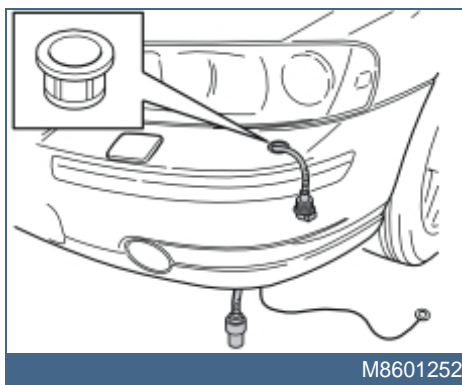

Applies to the V70

- Install the expander nut in the hole, with the guide pin in the guide hole.
- Route through the cable from the front socket, including the ground cable, from above and down. Let them hang down.

4

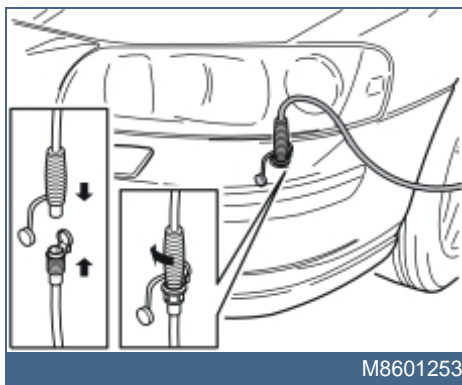

Applies to the V70 Installing the front engine block heater socket

- Connect the cable to the front socket. Press down and turn the cable clockwise so that the expander nut expands.
- Align the cable from the front socket so that the hinge points to the headlamp. Remove the cable.



5

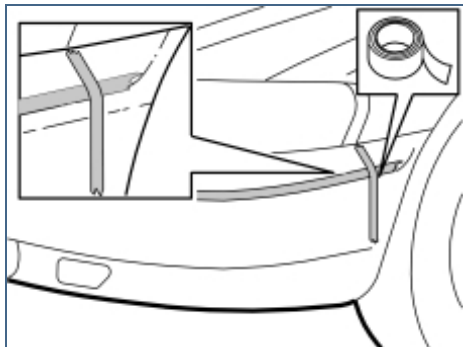

M8600602

Applies to the XC70 Preparations

- Clean the bumper cover where the two pieces of tape shall be adhered.
- Install the two pieces of tape for marking the holes for the engine block heater connector (use narrow tape). One piece of tape is fitted at the rear edge, under the corner of the indicator lamp, and vertically down. The second piece of tape's lower edge is fitted along the upper radius of the bumper cover as illustrated.

6

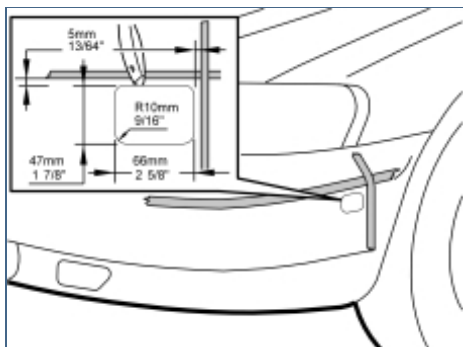

M8600603

Applies to the XC70

- Mark up a rectangle, in accordance with the measurements in the figure, on the inside of the corner of the point of intersection of the two pieces of tape. The distance from the tape edges must be **5 mm (13/64")**.
- Protect the bumper cover by applying tape to the surface to be cut.
- Carefully cut out from the bumper cover in accordance with the marking. Use a utility knife or similar.
- Smooth off the edges.

7

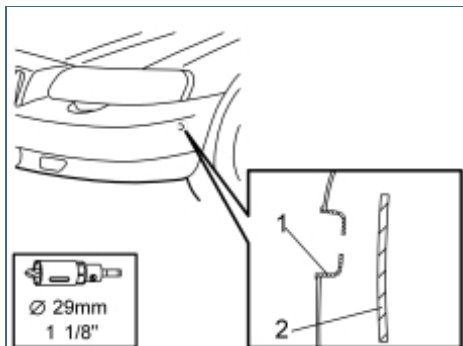

M8600604

Applies to the XC70 Installing the front engine block heater socket

- Remove the pieces of tape.
- Take the front socket's protective cover (1) from the kit and press it into the recess. The part of the protective cover where the hole is closer to the edge must point forward.
- Mark out the hole in the bracket (2) inside the bumper cover. Use a **Ø29 mm (1 1/8")** diameter hole saw without central drill bit.
- Remove the protective cover and drill out with the **Ø29 mm (1 1/8")** diameter hole saw.
- Remove any swarf.



8

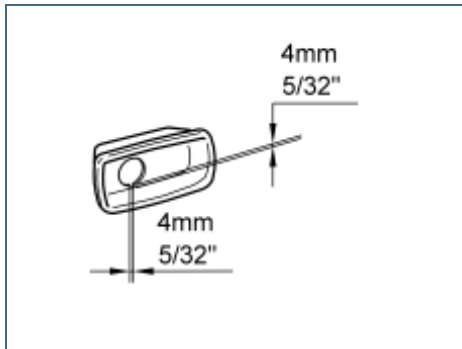

M8600605

Applies to the XC70

- File out a small recess, **4 x 4 mm (5/32" x 5/32")**, in the lower edge of the hole in the protective cover. The hole is designed for the pin on the expander nut, which is used for tightening the front socket.
- Reinstall the protective cover.

9

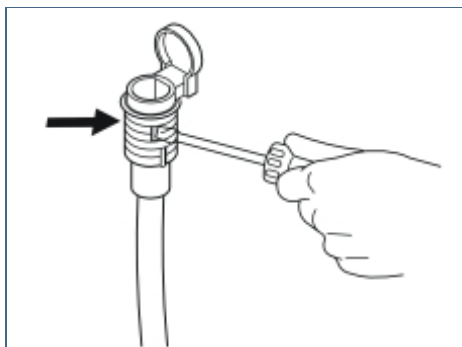

M3703484

Applies to the XC70

- Open the drainage holes on both sides of the connector. Use a screwdriver and press with manual force in the markings.

10

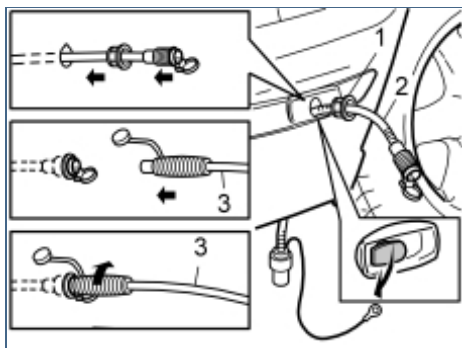

M8600606

Applies to the XC70

- Install the expander nut (1) in the hole.
- Guide down the enclosed cable (2), including the ground cable, through the hole.
- Take the connecting cable (3) from the kit. Fit it together with the cable at the expander nut. Screw clockwise so that the expander nut expands.
- Remove the connecting cable.

11

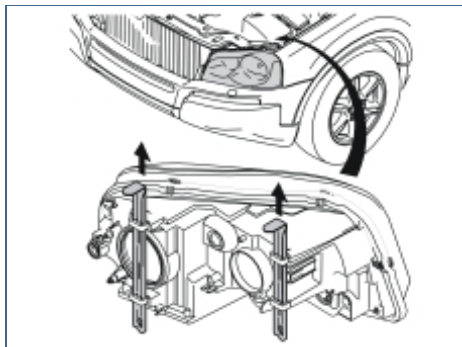

R3501343

Applies to the XC90 up to and including model year -2006

Preparations

- Detach the left-hand headlamp by pulling up the two locking pins and then carefully pulling away the headlamp forwards.



12

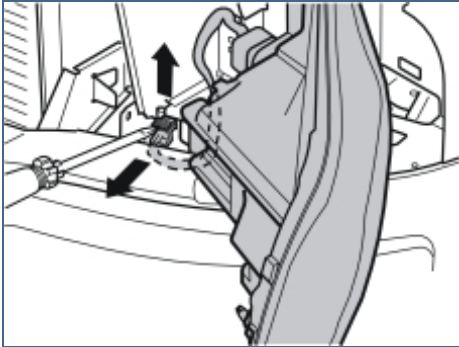

R3501493

Applies to the XC90 up to and including model year -2006

- Carefully prize up the catch on the connector for the headlamp with a screwdriver.
- Pull the catch up completely, detach the connector and place the headlamp to one side.

13

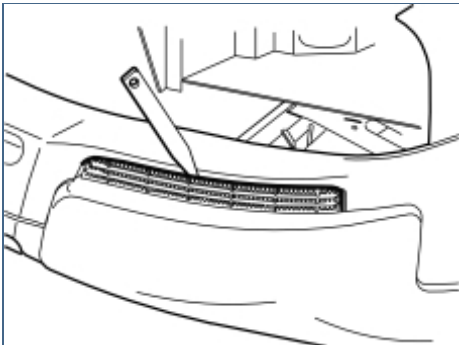

R8600944

- Remove the left-hand grille from the bumper by carefully prizing it away with a weatherstrip tool.

14

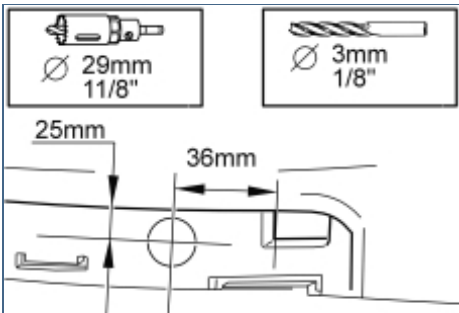

R8600921

- Measure out for drilling the front socket hole as illustrated.
- Pre-drill the hole using a $\text{Ø}3 \text{ mm}$ ($1/8$ ") bit.
- Drill out the hole. Use a $\text{Ø}29 \text{ mm}$ ($1 \ 1/8$ ") diameter hole saw.
- Remove any swarf.

15

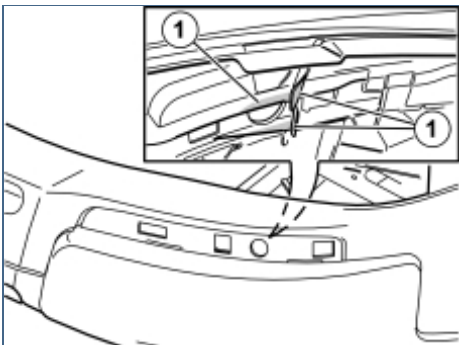

R8600945

- Take a utility knife and cut out the discs (1) in such a way that they are equally as high. The plastic nut for the front socket then has a flat surface to be tightened against.



16

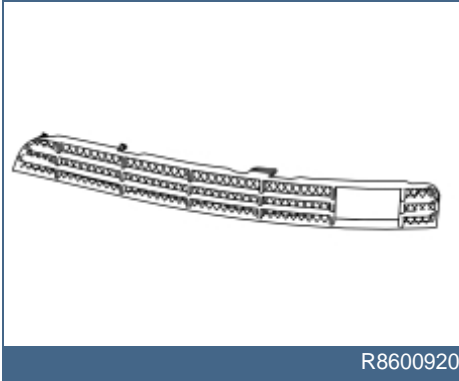

- Saw or cut out for the front socket connector in the second hole from the left in the left-hand grille of the bumper.
- Smooth off the edges.
- Press the grille into the bumper.

17A

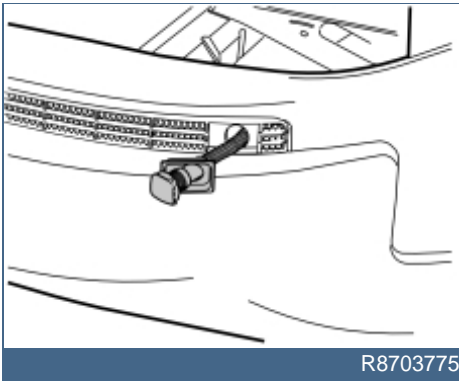

Installing the front engine block heater socket Illustration A

- Take the front socket, protective cover and plastic nut from the kit.
- Fit the protective cover on the front socket's connector and turn the connector so that the cover is opened to the left-hand side of the car as illustrated.

17B

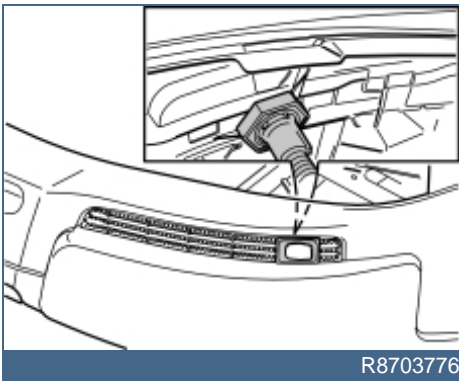
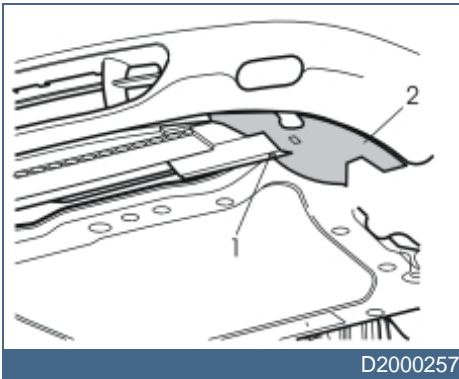

Illustration B

- Install the plastic nut.
- Tighten the plastic nut firmly. Connect the cable to the front socket for counterholding when the plastic nut is tightened.
- Route the cables down along the left-hand side of the left-hand side member.

18



Applies to the V70 and the XC70

- Raise the car.
- Remove:**
- the screw (1) from the left-hand air baffle (2).
 - the left-hand air baffle by pulling it backwards.
 - the right-hand air baffle in the same way.



19

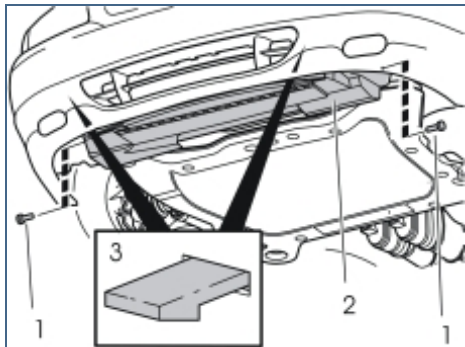

D2000214

Applies to the V70 and the XC70

- Undo the screws (1) of the centre air baffle (2) and remove it by pressing up the catches (3).

20

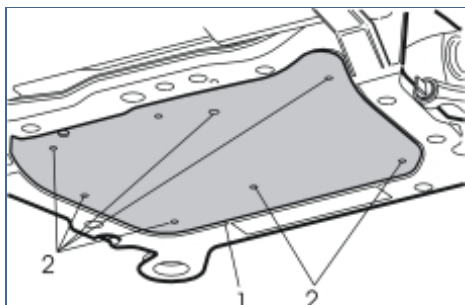

R2000348

Applies to the V70 and the XC70

- **Applies to the V70, XC70 and XC90 (up to and including MY 2006)**
- Remove the engine splash guard (1) by first removing the screws (2).

21

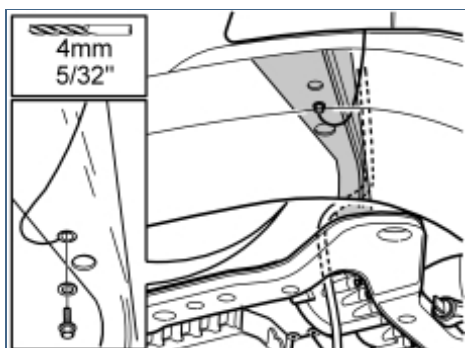

R8600915

Applies to the V70 and the XC70

- Drill a hole in the front/lower edge of the side member with a **Ø4 mm (5/32")** bit.
- Apply anti-corrosion agent and secure the ground cable with the enclosed **Ø4.8 mm (3/16")** flanged screw and toothed washer.

Note!

Connect the ground cable to the side member, not to the subframe.

- Secure excess ground cable with a tie strap.

22

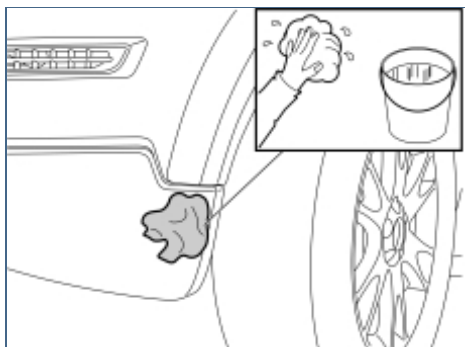

IMG-231722

Applies to the XC90 from model year 2007- Preparations

- Clean the bumper cover where the front engine block heater socket shall be secured.



23

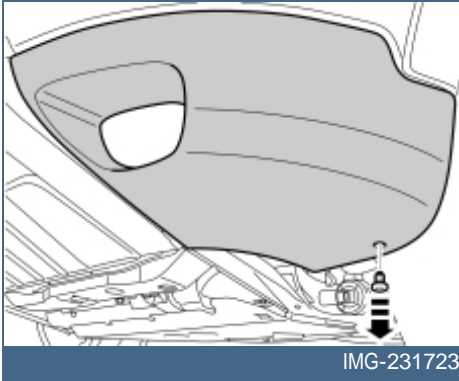

Applies to the XC90 from model year 2007-

- Remove the clip on the panel for the front fog lamp.

24

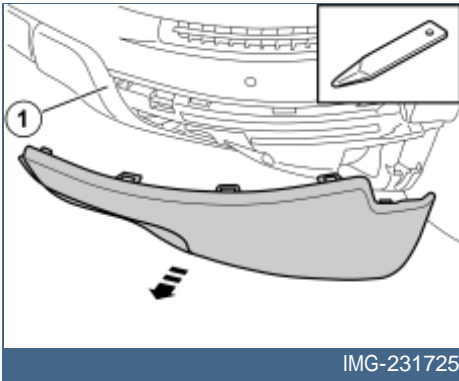

Applies to the XC90 from model year 2007-

- Remove the panel above the front fog lamp by carefully prizing it loose from the bumper cover using a weatherstrip tool. It is secured all round with catches.

25

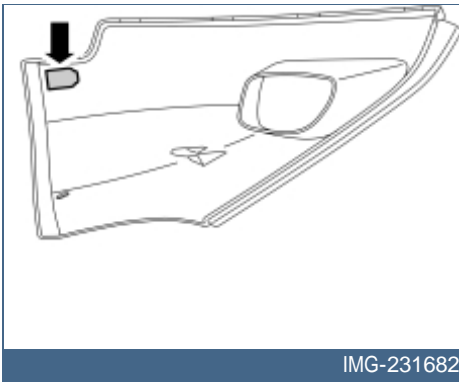

Applies to the XC90 from model year 2007-

- Cut out according to the existing marking on the inside of the panel for the protective cover for the front engine block heater socket.
- Test and cut until the protective cover fits.

26

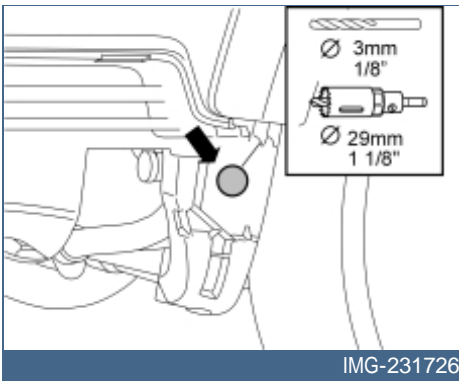

Applies to the XC90 from model year 2007-

- Pre-drill the hole using a $\text{Ø}3 \text{ mm}$ ($1/8''$) bit.
- Drill a $\text{Ø}29 \text{ mm}$ ($1 \text{ } 1/8''$) diameter hole using a hole saw according to the existing marking in the lower edge of the bumper cover.

Note!

It is important that the hole is drilled right in the centre of the marking in order to correspond with the hole cut out earlier.

- Even out the hole edges and remove the drill swarf.



27

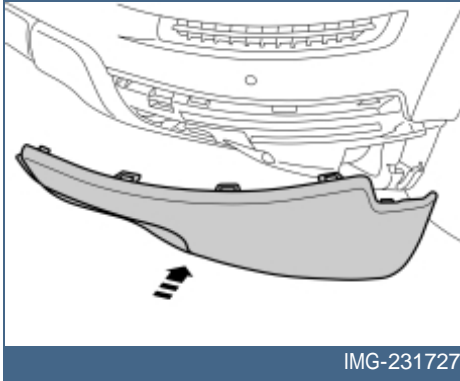

IMG-231727

Applies to the XC90 from model year 2007-

- Reinstall the front fog lamp panel.

28

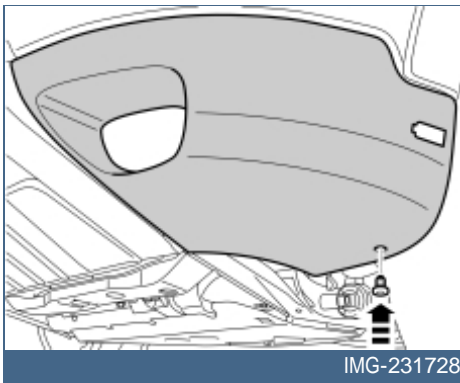

IMG-231728

Applies to the XC90 from model year 2007-

- Press the clip into the panel.

29

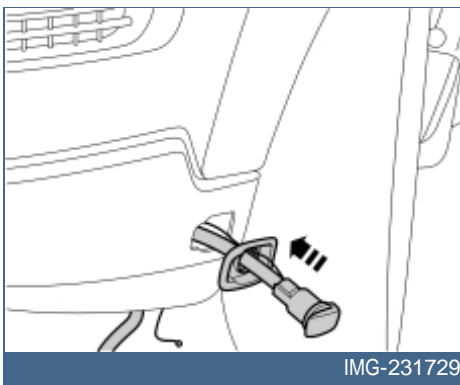

IMG-231729

**Applies to the XC90 from model year 2007-
Installing the front engine block heater socket**

- Press the protective cover (from the kit) into place in the hole cut in the bumper cover.
- Take the cable for the front engine block heater socket with ground lead from the kit and insert through the protective cover.

30A

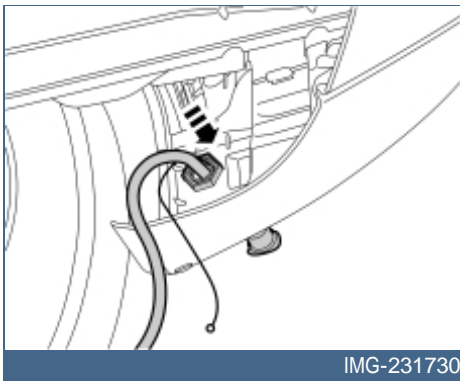

IMG-231730

Applies to the XC90 from model year 2007-

Illustrations A and B

- Install the nut from the kit.
- Rotate the connector for the front engine block heater socket so that the cover opens backwards (Illustration B).
- Tighten the front engine block heater socket to the bumper cover.
- Plug the electrical connector into the front engine block heater socket. Use the connector as a counterhold when tightening.



30B

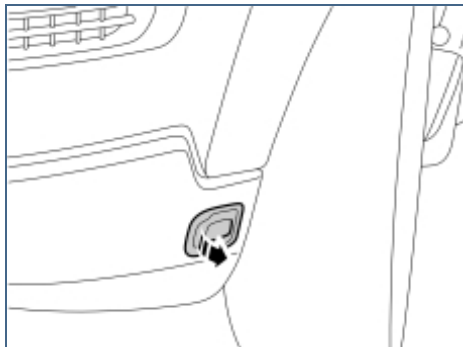

IMG-231731

- Remove the cover on the radiator expansion tank.

31

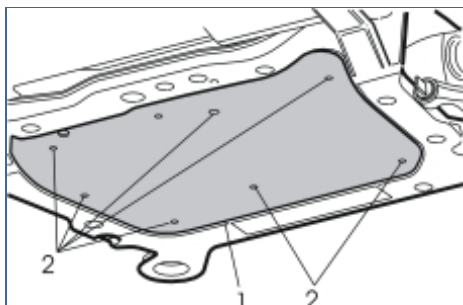

R2000348

Applies to the XC90 from model year 2007-

- Remove the engine splash guard (1) by first removing the screws (2).

32

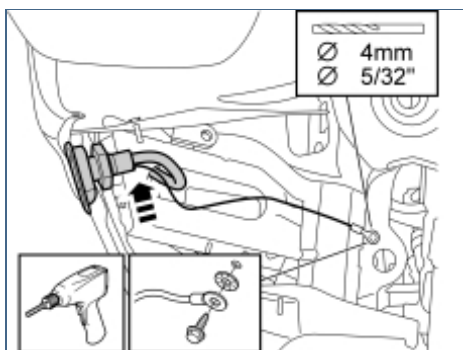

IMG-231732

Applies to the XC90 from model year 2007-

- Drill a hole in the front/lower edge of the side member with a **Ø4 mm (5/32")** bit.
- Apply anti-corrosion agent and secure the ground cable with the enclosed **Ø4.8 mm (3/16")** flanged screw and toothed washer (under the screw head).

Note!

Connect the ground cable to the side member, not to the subframe.

- Secure the excess ground cable length with a tie strap from the kit.

33

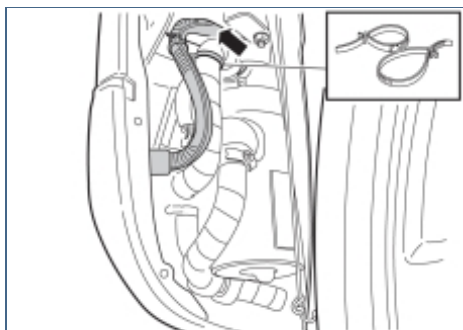

IMG-240661

Applies to the XC90 from model year 2007-

Step 33 applies to cars with fuel-driven parking heater installed

- Route the cable to the front intake with ground cable along the parking heater induction pipe. Secure them to the pipe with a double tie strap.
- Pull up the ground cable on the upper side of the plate where the connector to the fuel heater is located, and pull the thick cable underneath the plate.



34

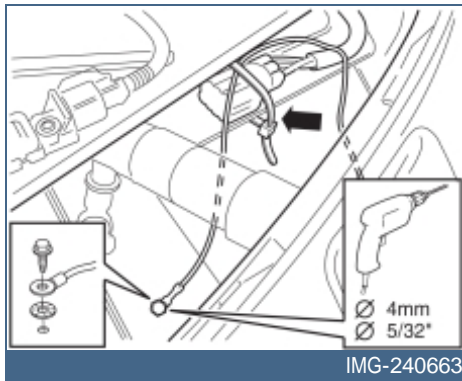

Applies to the XC90 from model year 2007-

Step 34 applies to cars with fuel-driven parking heater installed

- Drill a hole in the front/top edge of the side member with a $\varnothing 4$ mm (5/32") bit.
- Apply anti-corrosion agent to the edges of the holes and secure the ground cable with the enclosed $\varnothing 4.8$ mm (3/16") flanged screw and toothed washer.
- Secure the excess length of ground cable with a tie strap from the kit. Clamp it at the grey connectors of the parking heater.

35

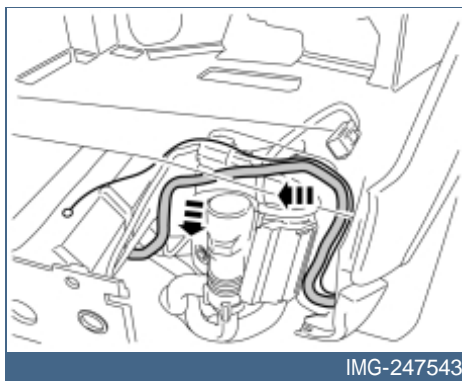

Applies to the XC90 from model year 2007-

Step 35 applies to cars with fuel-driven parking heater installed

- Continue routing the thick cable on top of the fuel heater along the cables there. Then pull it under the plate where the connector for the fuel heater is, continuing underneath the side member, before the front mounting for the subframe.

36

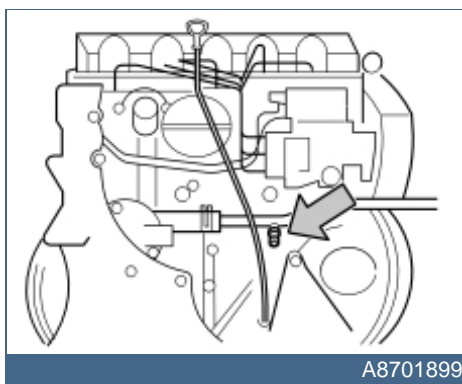

Installing the engine block heater, applies to all car models

- Open the cap for the radiator's expansion tank.
- Position a collection container under the engine and open the coolant cock.
- Drain the coolant and close the cock.

37

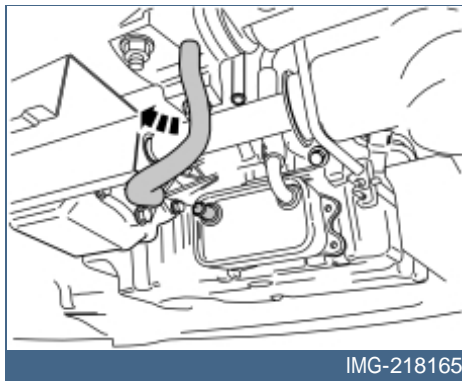

Installing the engine block heater, applies to all car models

- Remove the left cooling hose of the oil cooler and put it aside. The kit contains a new hose.



38

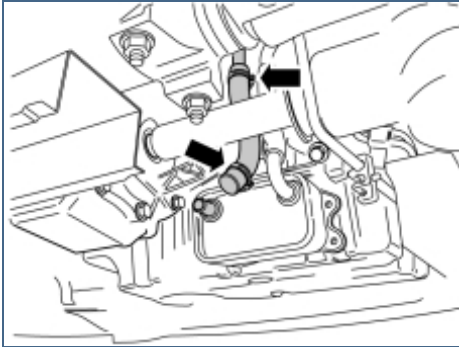

IMG-256425

Installing the engine block heater, applies to all car models

- Take a new cooling hose and two hose clips from the kit. Fit the new cooling hose in the cooling pipe instead of the old one.
- Fit the hose clips on the cooling hose, but do not tighten them.

39

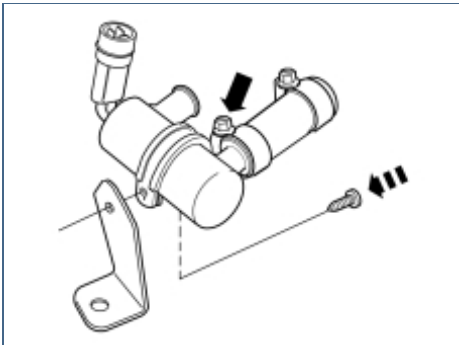

IMG-256426

Installing the engine block heater, applies to all car models

- Take the bracket, rubber-clad clamp, two hose clips, heater and screw from the kit. Assemble them as illustrated.
- Tighten the hose clip closest to the heater.

40

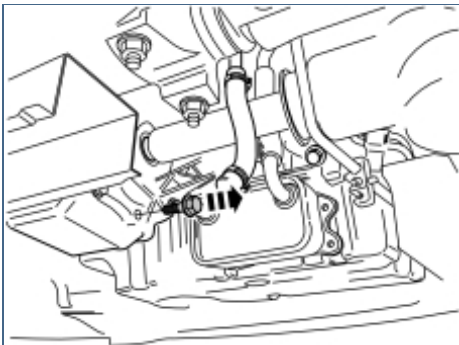

IMG-218168

Installing the engine block heater, applies to all car models

- Remove the screw in the right end of the angle gear.

41

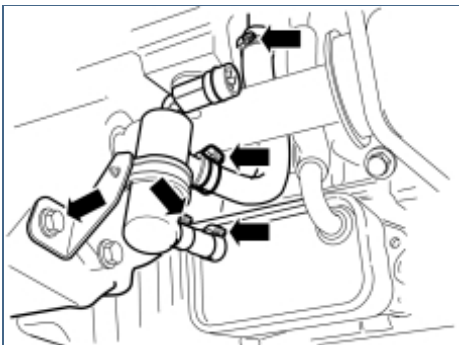

IMG-256427

Installing the engine block heater, applies to all car models

- Position the heater at the rear edge of the oil cooler and fit the hoses on the heater pipes/pipes in the oil cooler.
- Secure the heater bracket to the angle gear using the existing screw.
- Turn the bracket so that its narrow extension touches the front lower screw of the angle gear.
- Check that the cooling hoses are properly fitted and that the upper hose does not rub against the top edge of the oil cooler.
- Tighten all hose clips.
- Tighten and torque tighten the screw in the angle gear and bracket to **50 Nm (37 lbf.ft.)**.



42

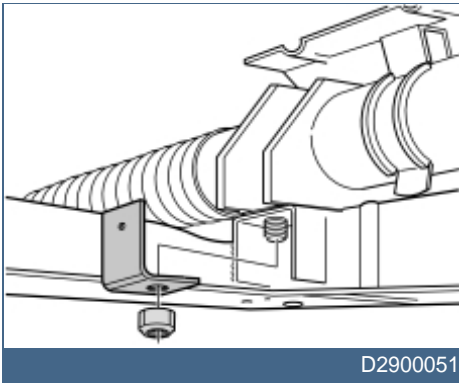

Installing the engine block heater, applies to all car models

- Remove the existing nut from the steering gear.
- Install the bracket for mounting the branching connector and cables.
- Install the enclosed lock nut. Tighten to **48 Nm (36 lbf.ft)**.

43

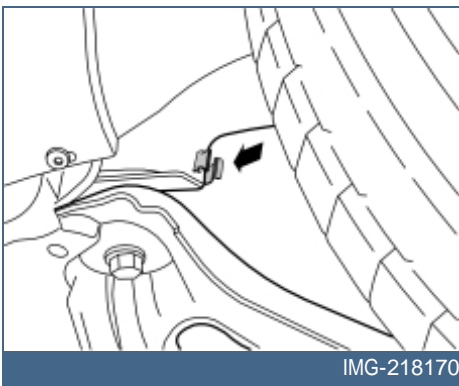

Installing the engine block heater, applies to all car models Steps 43 - 45 apply to cars with gearbox AWF21

- Take a clip from the kit and bend aside the front edge of the left front wing liner. Press the clip onto the edge of the left front corner of the subframe as illustrated.

44

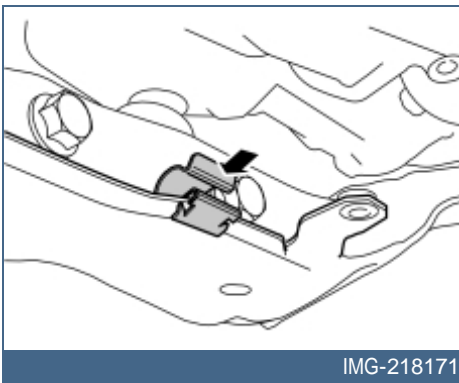

Installing the engine block heater, applies to all car models

- Take a clip from the kit. Press it onto the edge of the subframe near the front of the link arm nuts as illustrated.

45

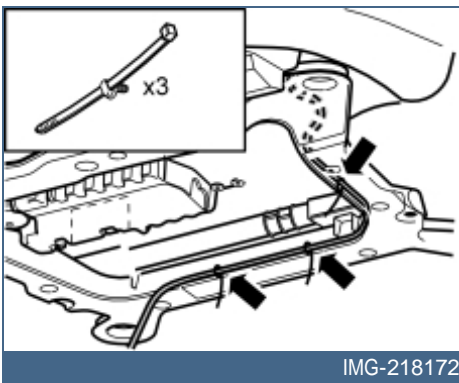

Installing the engine block heater, applies to all car models

- Take three tie straps with clip from the kit and press them into the holes on the inside of the subframe.
- Route the cable from the front socket to the left front mounting on the subframe. Press the cable into the first clip (Illustration 43) and route the cable diagonally down toward the second clip (Illustration 44) and press it into place.
- Secure the cable in the installed tie straps and route it back to the cable from the engine block heater. This routing prevents the cable from being pinched between the subframe and the gearbox.



46

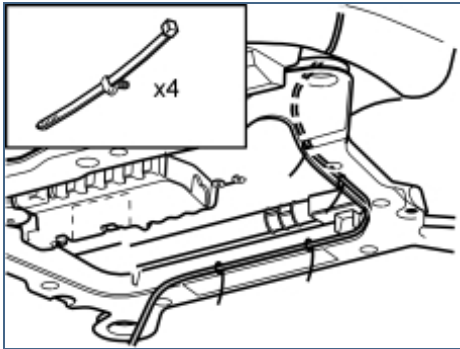

R8703667

Installing the engine block heater, applies to all car models
Applies to cars with other gearbox

- Take four tie straps from the kit and press them into the holes on the inside of the subframe.
- Route the cable from the front socket above the front edge of the subframe and back to the cable from the engine block heater.
- Clamp the cable securely into the fitted tie straps.

47

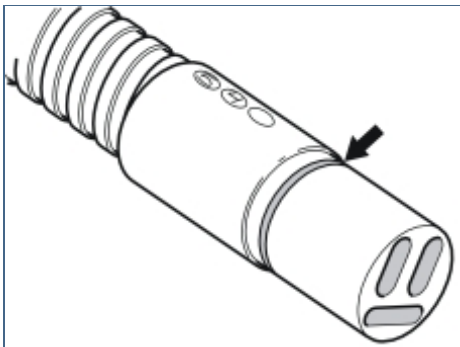

D3601932

Installing the engine block heater, applies to all car models

- Take the heater's short jointing cable from the kit. Lubricate the O-ring on the connector with low temperature grease **part no. 1161417-9**.
- Lubricate the O-ring on the connector of the newly routed cable to the front socket.

Note!
 Do not get any grease on the surfaces of the connector.

48

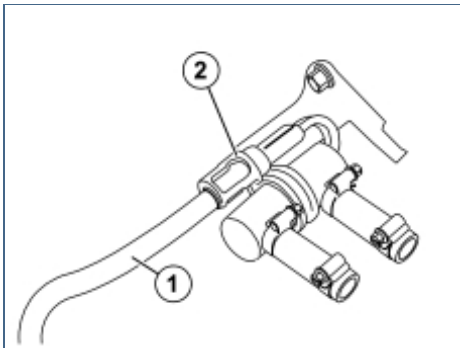

IMG-218173

Installing the engine block heater, applies to all car models

- Connect the jointing cable (1) to the heater's connector.
- Install the locking sleeve (2) from the kit over the joint between the heater and the cable.

49

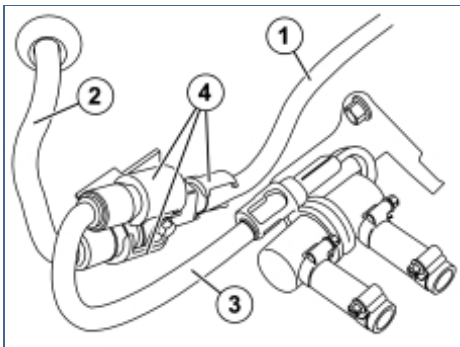

IMG-218174

Installing the engine block heater, applies to all car models
Applies if engine block heater and passenger compartment connector shall be fitted at the same time

- Take the branching connector from the kit. Lubricate the O-rings with low temperature grease (part no. 1161417-9).
- Fit the branching connector on the bracket with the screw and nut from the kit. Tighten.
- Connect the cables from the front socket (1), the passenger compartment socket (2) and the engine block heater (3) to the branching connector.
- Press the locking sleeves (4) from the kit over the joints.



50

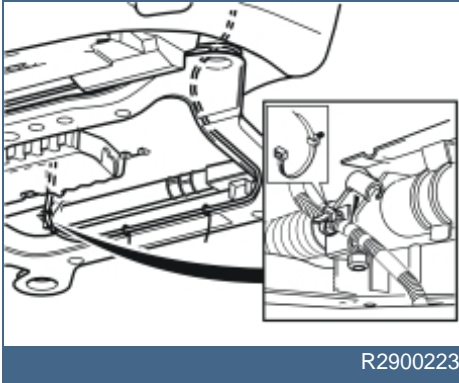

Installing the engine block heater, applies to all car models Applies if an engine block heater only is to be installed

- Connect the cable from the front socket to the cable from the engine block heater.
- Take the locking sleeve from the kit and press it over the joint.
- Take a clamp from the kit and press it into the hole on the previously installed bracket.
- Clamp the cable in at the bracket as illustrated.

Caution!

The cable must not be secured to the drive shaft, to the fuel lines, air conditioning (A/C) pipes or brake pipes. Ensure that the cable is not rubbing against any sharp edges and that it is not too close to the turbocharger (TC) or exhaust pipe to prevent damage from radiant heat.

51

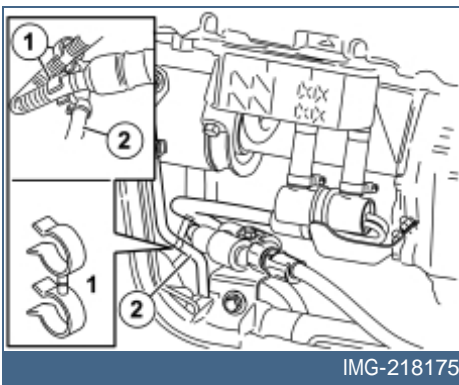

Installing the engine block heater, applies to all car models Applies to all models

- Take the two attaching clamps (1) from the kit. Use them to secure the cable from the engine block heater at the servo line pipe (2). This prevents the cable and pipe chafing against each other.

52

Installing the engine block heater, applies to all car models

- Fill with coolant, drive to normal operating temperature and check for any leaks.

Applies V70/XC70

- Reinstall the centre air baffle.
- Reinstall the two air baffles at the sides.
- Reinstall the engine splash guard. Torque tighten the screws to **25 Nm (18.5 lbf.ft.)**.

Applies to the XC90

- Reinstall the engine splash guard. Torque tighten the screws to **25 Nm (18.5 lbf.ft.)**.
- Connect the headlamp and reinstall it.