



XC90

Section	Group	Weight(Kg/Pounds)	Year	Month
8	87		2002	09

XC90 2003 B5254T2, XC90 2004 B5254T2, XC90 2005 B5254T2 AW50/51 AWD, XC90 2005 B5254T2 AW55-50/51SN, XC90 2006 B5254T2, XC90 2006 B5254T2 AW50/51 AWD, XC90 2006 B5254T2 AW55-50/51SN, XC90 2007 B5254T2, XC90 2007 B5254T2 AW50/51 AWD, XC90 2007 B5254T2 AW55-50/51SN, XC90 2008 B5254T2, XC90 2008 B5254T2 AW50/51 AWD

B5254T2

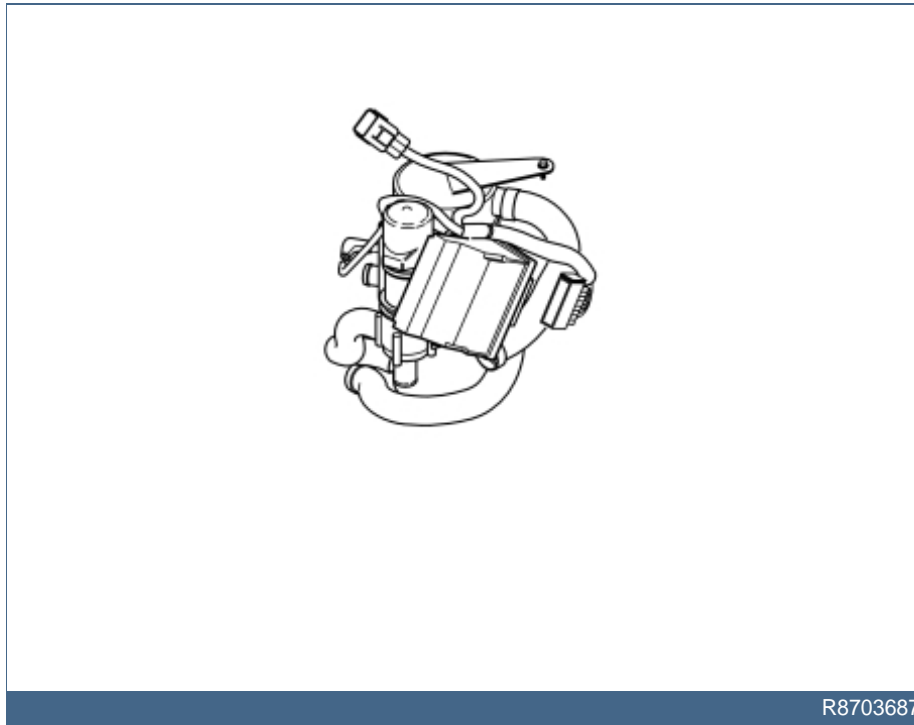

Installation instructions, accessories - Fuel driven heater 912-B

Volvo Car Corporation Göteborg, Sweden



Required tools

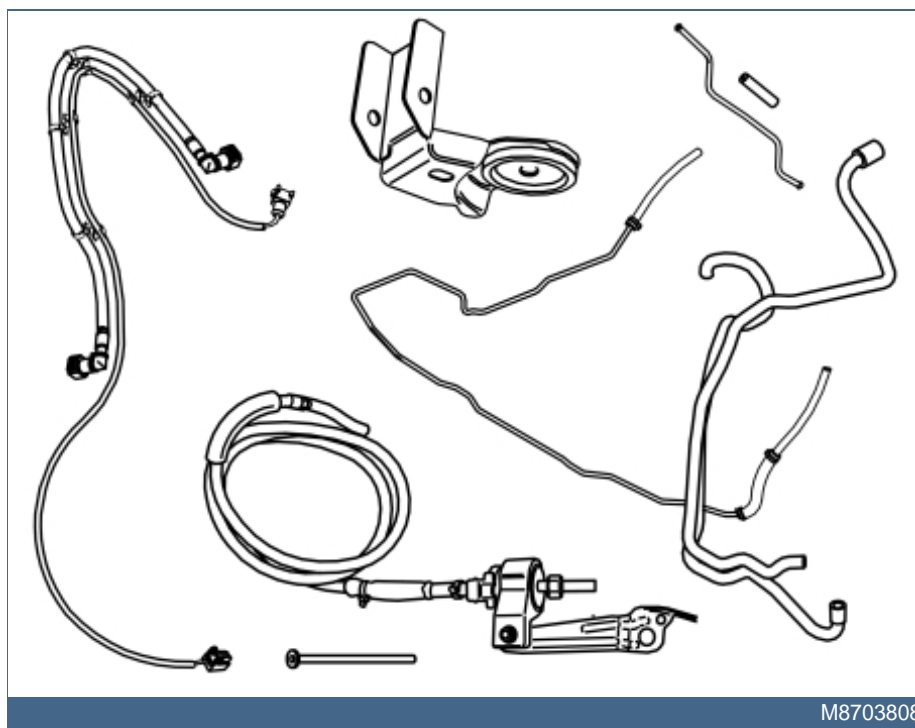
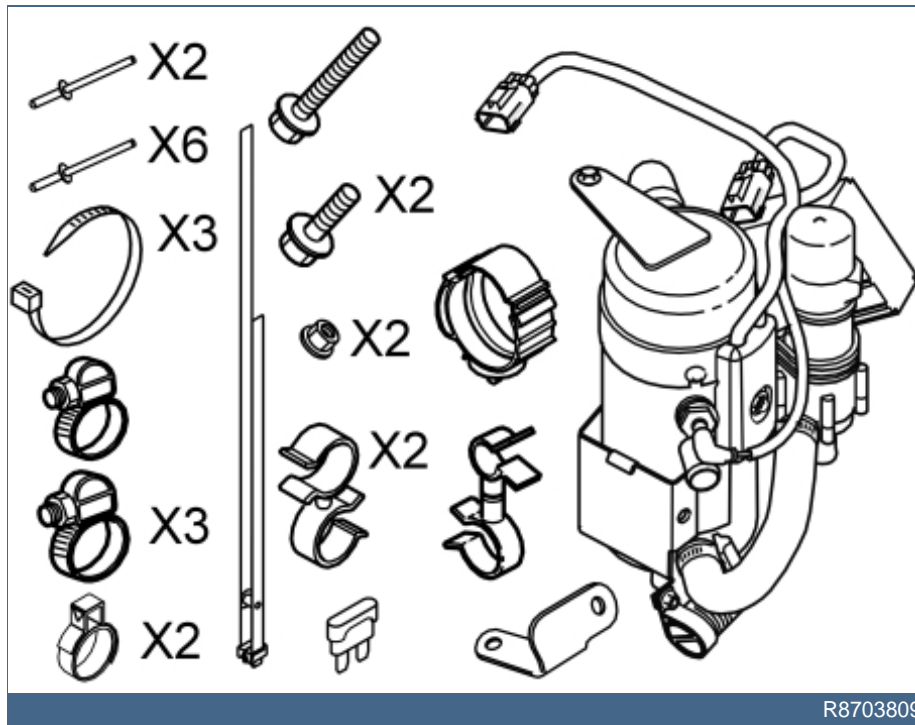
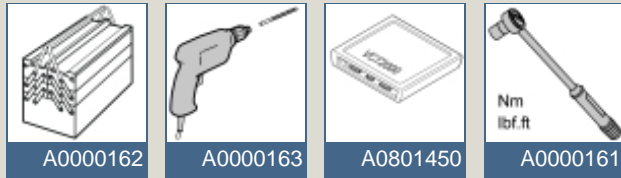



Any comments on this publication? Please contact your nearest dealer. Thank you!

Publication no: MA 8637062, Issue: 2002-09
Comments:.....
From:.....
Address:.....
Telephone no:.....
Telefax:.....



INTRODUCTION

- **NOTE! Read through the entire text before carrying out any work.**
- The front page gives the date of this edition and the edition it replaces
- The second page shows the tools needed for the installation and the contents of the installation kit
- The illustrations display the procedure in order of operation. The order of operation is repeated in the text section
- Cut out the text page in order to follow the illustrations and text at the same time.

Fuel driven heater 912-B

Note!

This accessory requires software unique to the car.



1

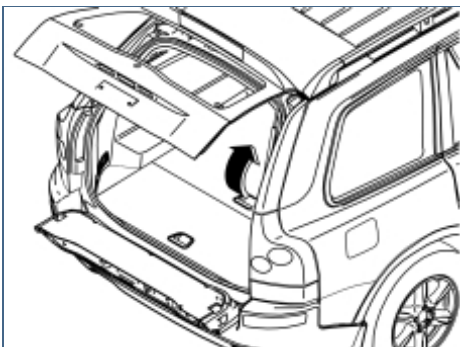

R8504235

Applies to cars with two rows of seats

- Remove the front floor hatch. First lift up slightly and then pull the hatch loose from its mountings at the front edge.

2

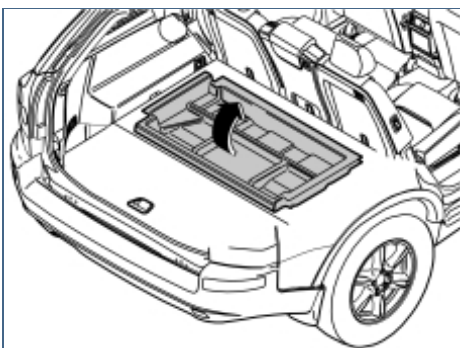

R8504236

Applies to cars with two rows of seats

- Lift out the front storage compartment.

3

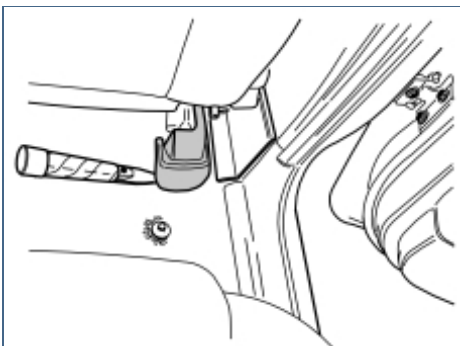

R8504241

Note!

Removing the right-hand seat in the second row of seats (steps 3-8) applies to all cars. For cars with three rows of seats, the left-hand and centre seats in the middle row must also be removed. See step 9.

- Remove the panel on the right rear mounting on the right-hand front seat. Pry up the rear edge of the panel slightly and then pull backwards and upwards.

4

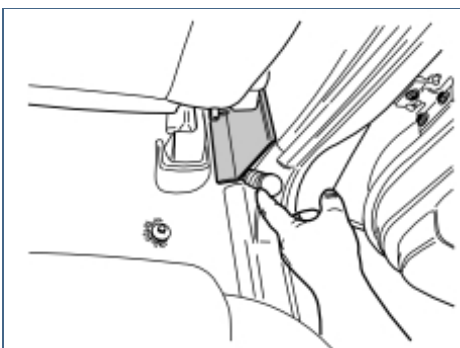

R8504169

- Slide the seats in the first row as far forwards as possible
- Carefully pry off and remove the panel above the joint between the right-hand door sills.



5

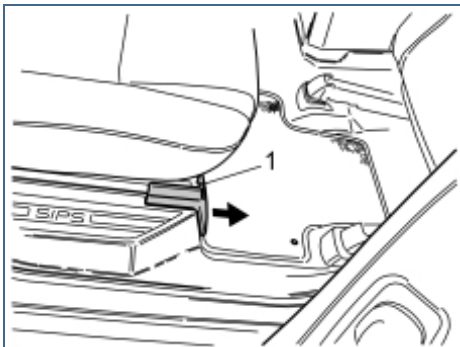

R8504171

- Remove the panel for the front right seat mounting on the right-hand seat in the second row. Press down the catch (1) on top and detach the panel by pulling it forward. Remove the screw underneath.

6

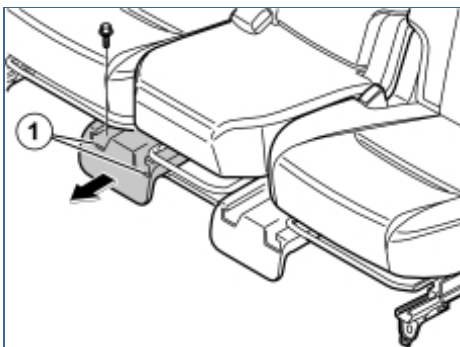

R8504243

- Remove the panel for the front seat mountings for the right-hand seat/middle seat in the second row. Press down the catches (1) on top and detach the panel by pulling it forward. Remove the screw for the right-hand seat.

7

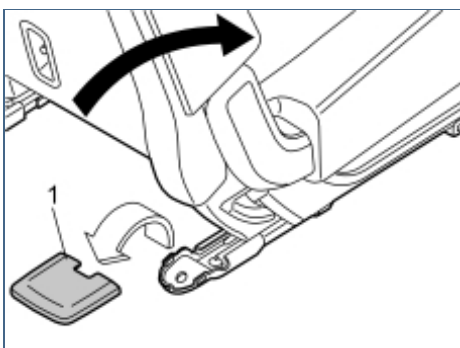

R8504247

- Fold the rear backrest forwards on the right-hand seat in the second row
- Remove the covers (1) for the rear seat mountings on the right-hand seat by prying them off the rear edge. Remove the screws.

8

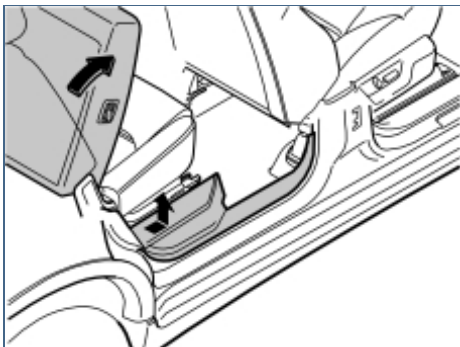

R8504234

- Remove the sill trim panel for the right-hand rear door. Pull off the rear edge until the clips release. Continue forwards until the remaining clips have released
- Unhook the sill trim panel from the B-post panel. Place the sill trim panel in the cargo compartment
- Remove the seat.

Caution!

Be careful when lifting the seats out of the passenger compartment. Ensure that the mountings do not damage the door panels.

9

Applies to cars with three rows of seats

- Remove the corresponding panels and screws as in steps 3-8, on the left-hand



side, and for the left-hand and middle seats in the second row

- Remove the left-hand and centre seats.

Caution!

Be careful when lifting the seats out of the passenger compartment. Ensure that the mountings do not damage the door panels.

10

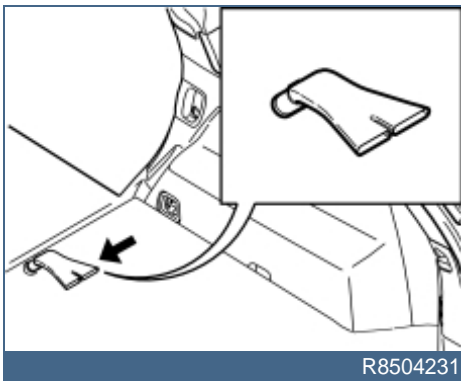

Applies to cars with three rows of seats

- Remove the vents on the right and left-hand sides.

11A



Illustration A applies to cars with two rows of seats

- Push the floor carpet to one side and secure it using the seat belt on the left-hand side
- Carefully push the insulation to one side so that the cover for the fuel tank unit is accessible.

Caution!

Take care with the insulation. It will break off easily.

11B

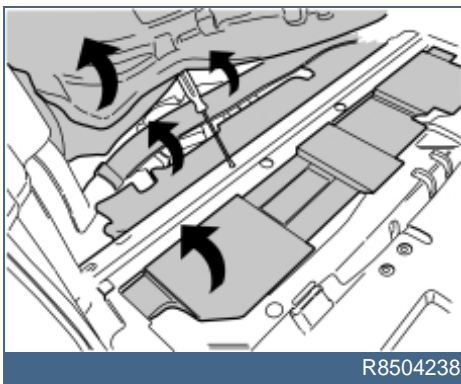
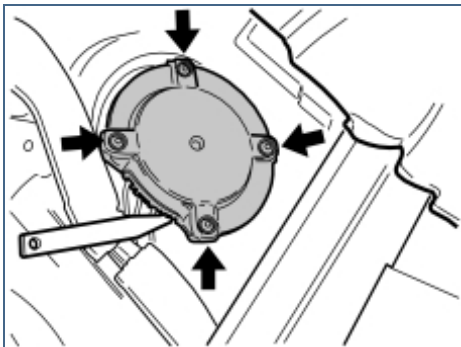

Illustration B applies to cars with three rows of seats

- Push the floor carpet and insulation panel to one side
- Position a screwdriver or similar to hold the carpet in place
- Remove the air duct
- Remove both insulation panels.



12



R8504239

- Remove the four screws in the cover for the fuel tank unit
- Carefully pry off the cover. Use a weatherstrip tool.

13

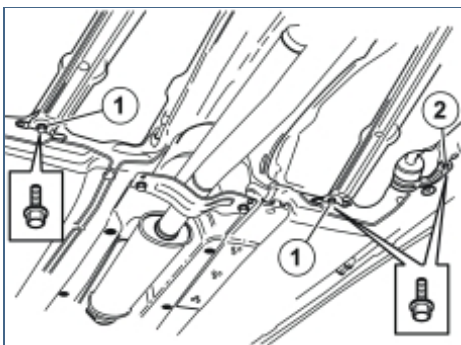

R2501320

- Remove the four screws (1) in the front and rear mountings for the fuel tank so that the fuel tank lowers slightly. This allows the suction pipe for the fuel tank to be installed. If necessary, remove the screw (2) for the fuel filter to lower the fuel tank further.

14

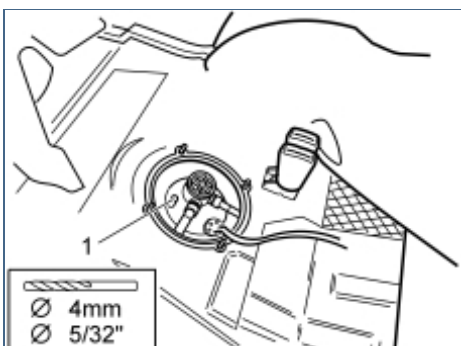

R2302950

- Drill out the terminal (1) in the fuel tank unit. Use a **4 mm (5/32")** diameter drill bit.

Note!

Use a compressed air power drill with a greased bit.

15

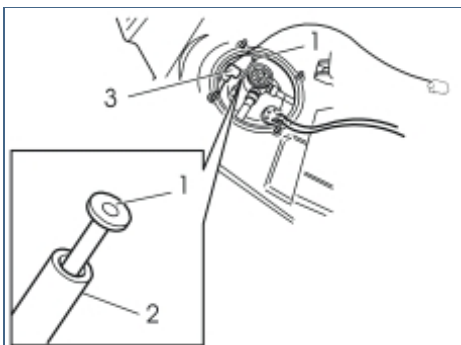

R2302951

- Insert the pipe (1) from the kit into the connection (2). Press the pipe down until it is against the connection
- Take the fuel line and electrical cable from the kit. Apply masking tape on the end of the part of the fuel line that is to be inserted down through the hole in the floor (the end with the short free cable end)
- Insert the entire cable assembly (3) between the floor and the fuel tank out to the right.



16

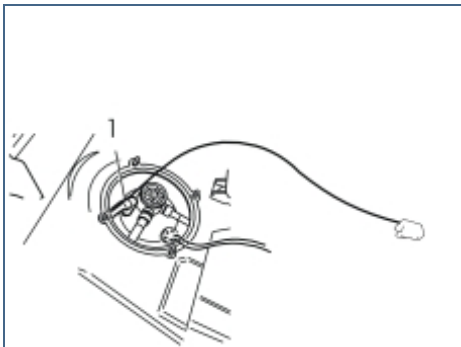

R2302952

- Press the quick-release connector (1) onto the connection until a click is heard. Check that the quick-release connector is secure.

17

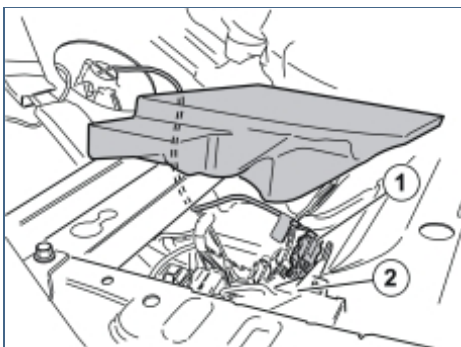

R3702953

- **Applies to cars with two rows of seats**
 - Carefully push up the end of the insulation.
 - Position a spacer underneath.
- **Applies to all models**
 - Route the cable that was previously routed along with the fuel line under the seat member. Connect the cable to the front connector (1) in the connector bridge (2)
- **Applies to cars with two rows of seats:** Remove the spacer and fold down the insulation
- Position the cable in the holder in the fuel tank unit cover
- Reinstall the cover for the fuel tank unit. Secure the cover using the four screws.

18

- Reinstall the insulation panels
- **Applies to cars with three rows of seats:** Reinstall the air duct
- Fold back the carpet
- **Applies to cars with three rows of seats:** Reinstall the vents under the outer seats
- Reinstall the seats.

Caution!

Be careful when lifting the seats into the passenger compartment. Ensure that the mountings do not damage the door panels.

- Secure the seats. Tighten the screws. Tighten to **48 Nm (35 lbf. ft.)**
- Reinstall the panels and covers over the seat mountings



- Reinstall the panels over the joint between the door sills.

Applies to cars with two rows of seats

- Reinstall the front storage compartment
- Reinstall the front floor hatch.

19

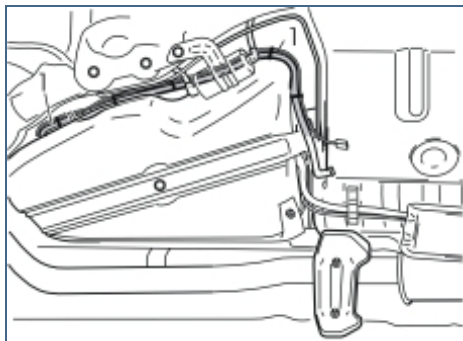

R2302954

- Route the fuel hose and cable harness (1) at the rear edge of the fuel tank. Route it along the right-hand side of the fuel tank and forwards. Let it hang down.

20

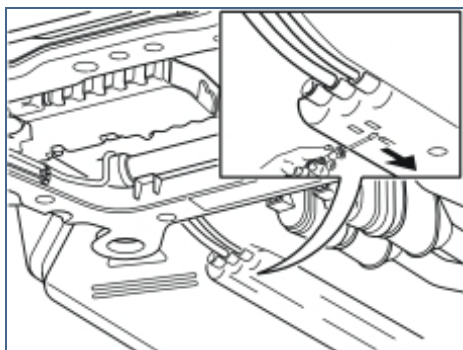

R2303046

- Disconnect the rail for the fuel line. Insert a small screwdriver in the small hole between the rail and the yellow clip. Slide the clip in the same direction as the oval hole in the rail. The rear black clip has a small collar on the clip. Position the screwdriver against the collar and slide it forwards.

21

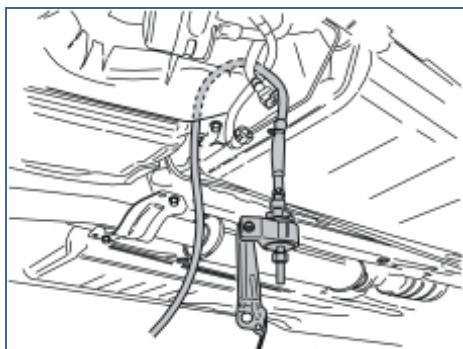

R2501322

- Take the fuel pump (FP) and cable from the kit. Slide the cable up at the front edge on the right-hand side of the fuel tank
- Route the cable so that it is next to the existing cable in the cut-out on top of the fuel tank. Then position the cable on the right-hand side of the wiring which runs to the engine compartment
- Pull up the wiring so that the fuel pump (FP) is positioned as approximately as illustrated.



22

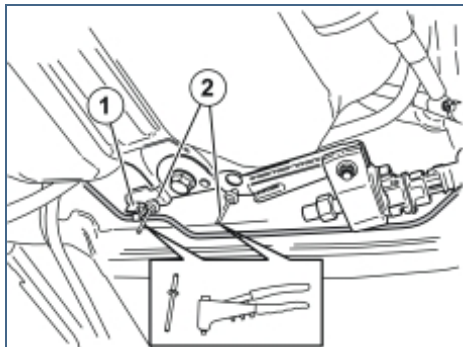

R2501323

- Remove the brake pipe (1) from the clamp
- Take the fuel pump (FP) and bracket. Position the bracket on top of the bracket for the fuel tank mounting, aligned with the small holes for the rivets
- Take two metal rivets (2) from the kit. Rivet the fuel pump bracket to the bracket for the fuel tank mounting.

23

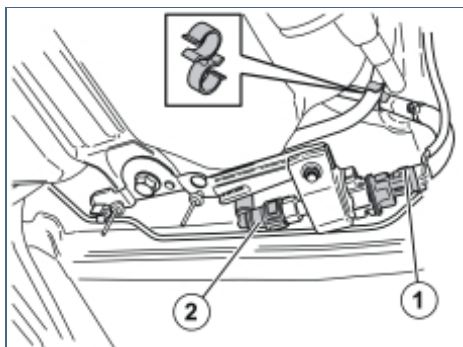

R2302955

- Take the double clamp from the kit. Secure the two fuel lines from the fuel pump (FP) to each other, opposite the two blue markings on the fuel lines
- Press the brake pipe back into the clamp
- Tighten the four screws securing the fuel tank. Tighten the screw for the fuel filter if it was loosened. Tighten the screws. Tighten to **24 Nm (18 lbf.ft)**
- Connect the connector (1) from the pre-routed power cable to the fuel pump (FP)
- Connect the quick-release connector (2) on the pre-routed fuel line to the fuel pump (FP).

24

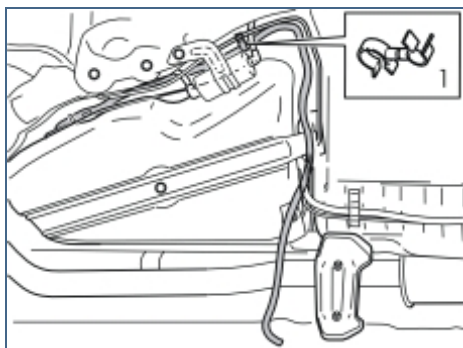

R2302956

- Take a double clamp from the kit. Clamp the fuel line to the brake pipe at point (1).

25A

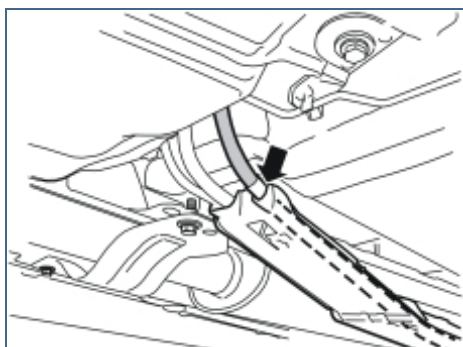

R2303048

- Press into place the fuel hose from the recently installed fuel pump (FP). Press into place in the bottom of the rail and forwards, in the cut-out furthest to the right.

Note!

The marking on the fuel hose must be opposite the point where the fuel hose goes into the rail.

- Slide back the retaining clip for the rail. Press the rail against the car body.



25B

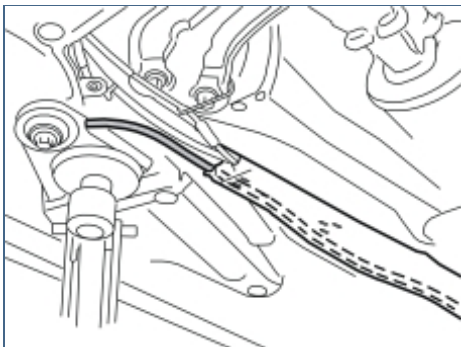

R2303062

Ensure that the rail is securely installed.

26

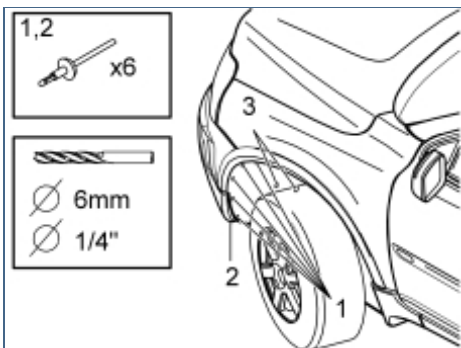

R8600959

- Remove the left front wheel
- Drill out the five rivets (1) holding the wheel arch lining and the rivets (2) in the lower edge of the bumper. Use a **6 mm (1/4")** diameter drill bit.

Remove:

- any rivet remains
- the plastic nuts (3) holding the wheel arch lining in place
- the small protective panel.

27

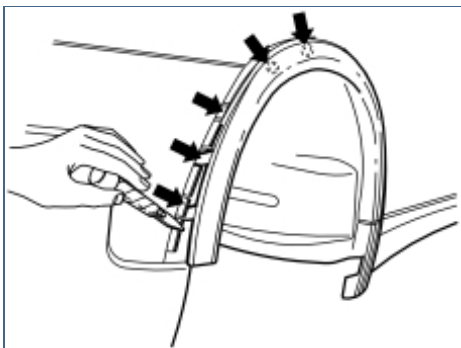

R8600966

Applies to cars with accessory side trim

Note!

- The side trim on the front wing must not be removed.

Only move the mounting lugs on the front wing side trim to one side so that the edge of the wheel arch lining can be exposed.

Applies to cars without accessory side trim

- Detach the wheel arch extension. Carefully pry off the wheel arch extension using a weatherstrip tool
- Pull the wheel arch extension up to the highest point until the three catches at the lower edge and the two clips slightly higher up have released.



28

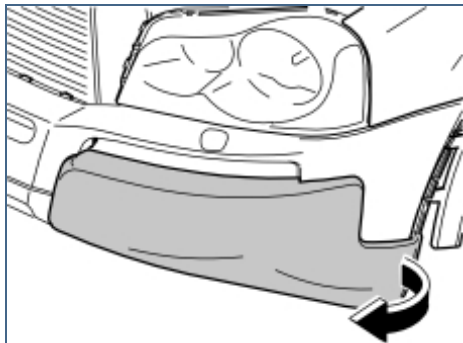

R8600961

- Remove the left-hand panel on the bumper by carefully pull off the left-hand lower edge until the clip at the bottom on the inside releases. Continue pulling until the clips around the panel release.

29

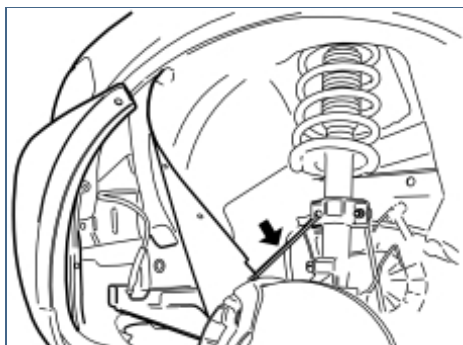

R8600965

- Push the wheel arch lining to one side. Secure with a tie strap or similar.

30

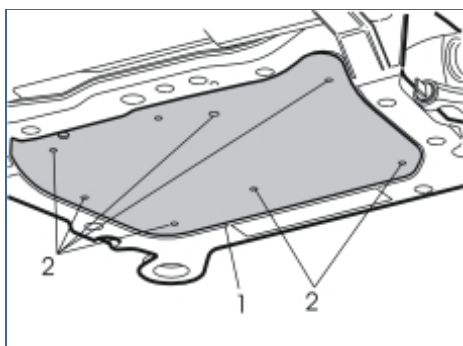

R2000348

- Remove the engine splash guard (1) by removing the screws (2).

31

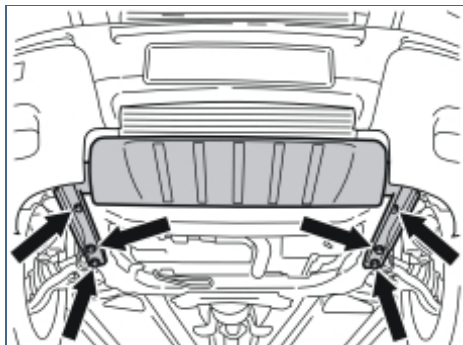

R2102465

- Remove the front skid plate. First remove the six screws (1) on the underneath
- With the assistance of a colleague, pull the skid plate forwards. Pull one of the corners until the mounting lug on that side of the skid plate releases from the sub-frame. Then pull off the other corner. The underside of the bumper cover may need to be carefully pushed down at the same time
- Open the cover for the radiator expansion tank
- Thread a hose onto the engine coolant drain nipple
- Open the drain nipple. Drain off the coolant.



32

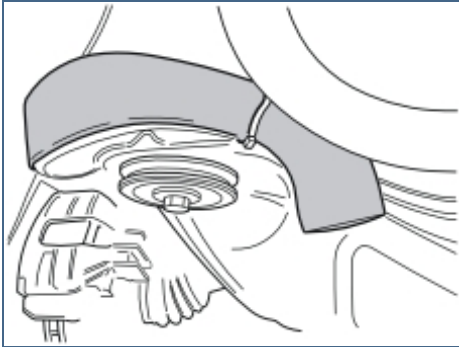

R2303064

- Pull off and push the pipe elbow to one side so that the fuel pipe can be positioned.

33

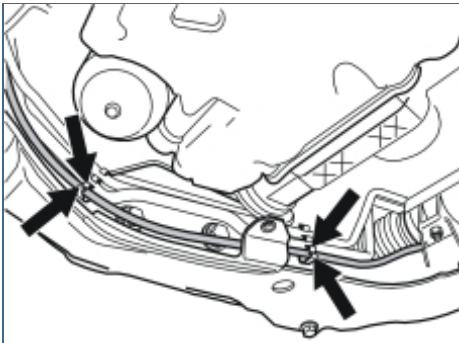

R2303065

- Remove the power steering pipes and the plastic hose from their clips to make installing the fuel pipe easier. In order to push the upper power steering pipe to one side, the rubber coated clamp on the upper side of the front edge of the sub-frame may need to be removed.

34A

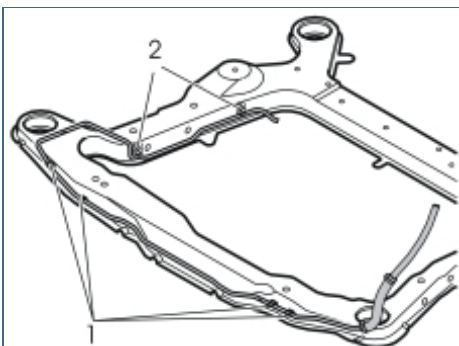

R2303047

- Install the fuel pipe using the four pre-installed clips (1) (from the kit) on the sub-frame. Insert the fuel pipe between the disconnected pipes and the sub-frame. Press the fuel pipe into place using the clips in the front edge of the sub-frame and in the bottom in the clips (2) that secured the plastic hose. Due to limited space, the fuel pipe needs to be worked slightly in order to position it.

- Reinstall the power steering pipes. Press the plastic hose into place on the outside of the fuel pipe. Reinstall the rubber coated clamp if this has been removed

34B

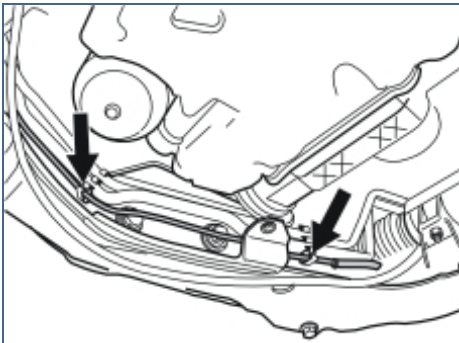

R2303066

- Check that the fuel pipe does not catch on the sub-frame. Check that the fuel pipe does not rub against pipes or screw heads for the suspension.



35

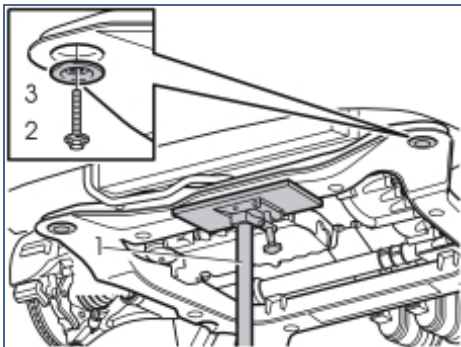

R6400811

- Reinstall the pipe elbow
- Install the jack (1) under the front edge of the sub-frame
- Take the weight off the sub-frame
- Remove the screw (2) and the washer (3) from the left front mounting on the sub-frame.

36

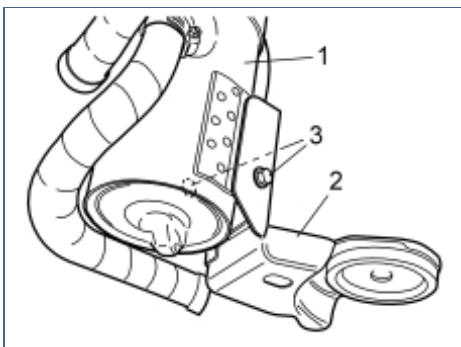

R8703683

- Install the heater (1) on the bracket (2.) Use the screws (3) from the kit. Tighten.

37

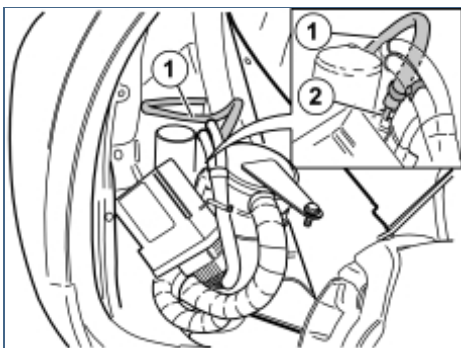

R8703684

- Slide the heater up to the installation position
- Take a small hose clamp for the fuel line from the kit. Install the hose clamp on the fuel hose (1) from the fuel pipe on the sub-frame
- Press the fuel line on the inlet (2) on the fuel pump (FP). Tighten.

38

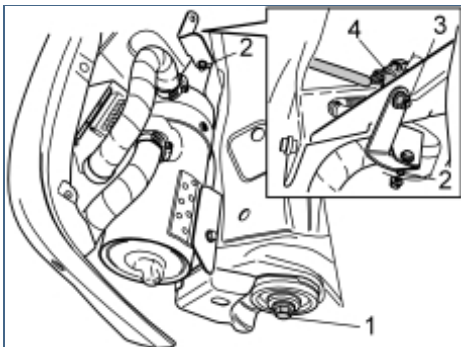

R8703685

- Take a new screw (1) from the kit. Secure the heater to the left-hand front corner of the sub-frame. Do not tighten fully yet
- Take the metal bracket and two nuts from the kit
- Install one of the mounting lugs for the metal bracket on the stud (2) on the heater. Install the nut. Finger tighten
- Install the other mounting lug for the bracket on the stud (3). Install the nut
- Tighten the heater to the sub-frame and the bracket. Tighten the screw (1). Tighten to **105 Nm (78 lbf.ft.)**. Angle-tighten to 120° or **max. 280 Nm (206 lbf.ft.)**
- Remove the protective cover from the pre-routed connector (4). Press in the catch on the top. Pull off the cover



- Connect the cable from the heater to the connector.

39

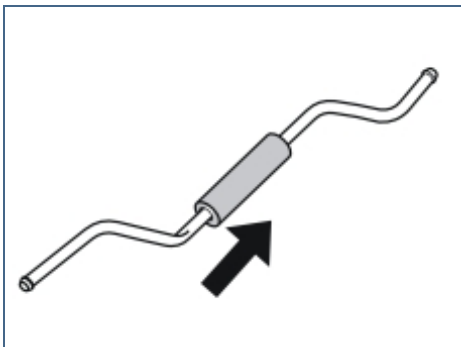

R2303052

- Take the chafe protection and the short fuel pipe from the kit. Install the chafe protection on the pipe.

40

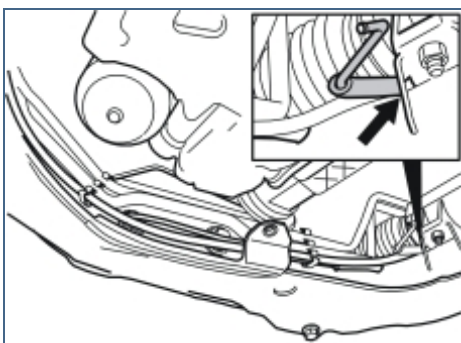

R2303067

- Insert the end of the short fuel pipe that is bent in two different directions, under the power steering and the anti-roll bar, over the right-hand rear corner of the sub-frame.

41

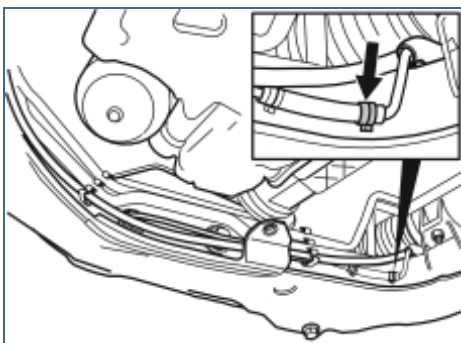

R2303068

- Take a hose clamp from the kit. Thread the hose clamp onto the short fuel line on the fuel pipe on the sub-frame
- Connect the short fuel pipe to the fuel line. Slide the pipe into the fuel line. Slide the pipe in so far that the two pipes are in contact with each other. This prevents air pockets from forming
- Squeeze the hose clamp together.

42A

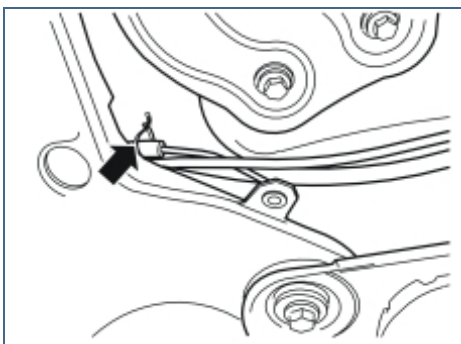

R2303069

Illustration A

- Take a tie strap from the kit. Clamp the protective tube at the fuel pipe so that it is securely installed.

Illustration B

- Take a hose clamp from the kit. Thread the hose clamp onto the fuel line up to the fuel pump (FP) that was routed previously. Connect the fuel line to the short fuel pipe. Slide the pipe into the fuel line. Slide the pipe so far in that the two pipes are in contact with each other. This prevents air pockets from forming



42B

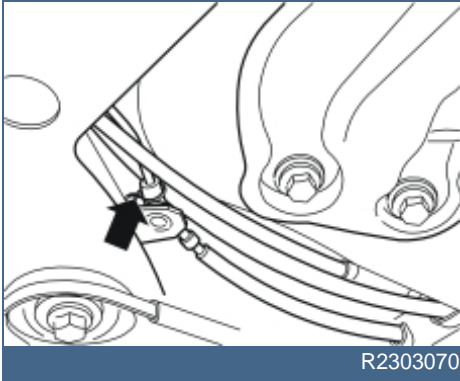

- Ensure that the fuel line is routed correctly and does not obstruct the plastic hose or rub against the sub-frame or other components
- Squeeze the hose clamp together.

Note!

Fuel lines and fuel pipes must be at least 15 mm (19/32") from brake pipes.

43

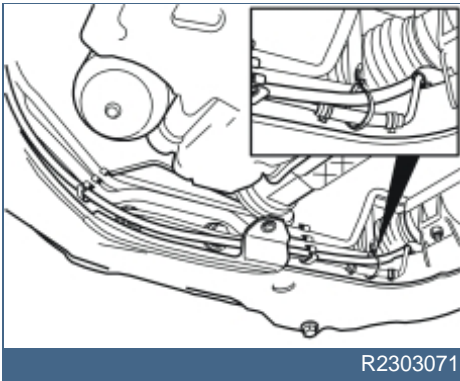

- Take a tie strap from the kit and clamp the fuel pipe at the plastic hose.

44

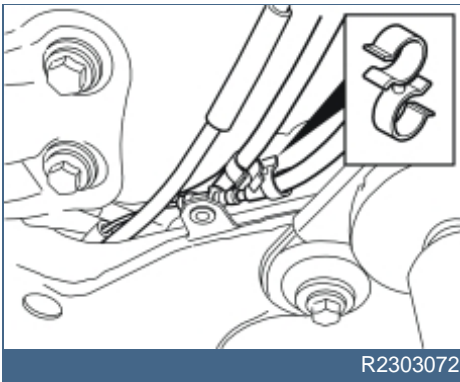

- Take a double clamp from the kit and clamp the fuel line for the parking heater at the ordinary fuel line.

45

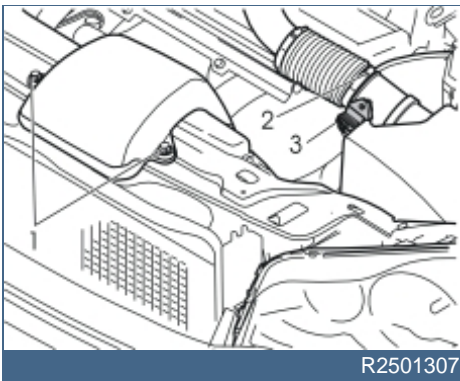

- Remove the two screws (1) from the intake manifold for the air cleaner (ACL)
- Remove the intake pipe. Place the intake manifold to one side
- Disconnect the hose clamp (2)
- Remove the connector (3) from the intake manifold for the turbocharger (TC)
- Pull off the air cleaner (ACL) from its mounting in the left-hand front member.



46

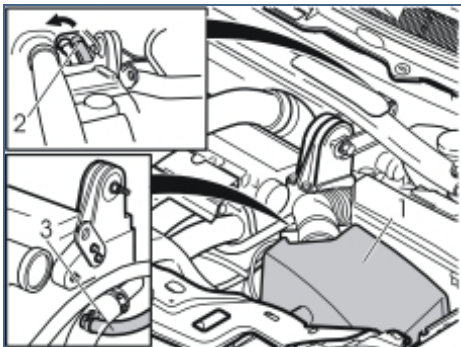

R2000371

- Pull the air cleaner (ACL) (1) up from its mounting on top of the front member. Turn it around in the intake hose. Move it away from the gearbox. Secure with string or similar. Depending on the version, more hoses or connectors may need to be detached from around the air cleaner (ACL)
- Disconnect the quick-release connector on the left heating hose (2) for the passenger compartment heater. Press in the circlip on the quick-release connector opposite the two arrows. Turn the circlip in the direction of the arrows at the same time. Turn the quick-release connector a little and pull it out
- Disconnect the heater hose (3) on the left-hand side of the cylinder head
- Place the heater hose to one side. It will not be reused.

47

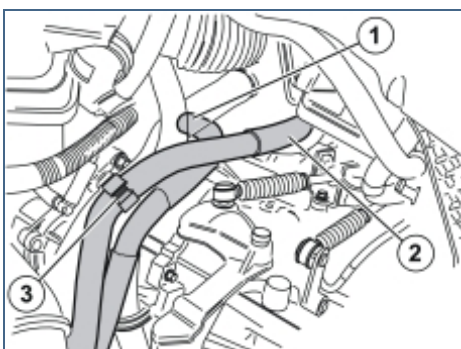

R2900237

- Thread the heater hoses from the kit down along the front left mounting of the sub-frame
- Route the hoses over the gearbox as illustrated
- Disconnect the thick coolant hose at the cylinder head. This facilitates the installation of the new coolant hose
- The hose (1) is connected to the left-hand side of the cylinder head using a hose clamp. Tighten the hose clamp. Connect the hose (2) to the left-hand hose connector in the cowl panel
- Take the plastic hose clamp (3) from the kit. Press the hose clamp into the top hole in the bracket on the gearbox
- Install the hose routed to the cowl panel in the clamp. Close the clamp.

48

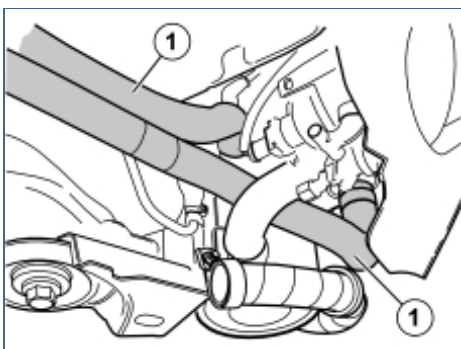

R8703686

- Connect the two heater hoses (1) to the heater using the hose clamps from the kit. Tighten the hoses.

49

- Tighten the drain nipple on the radiator. Remove the hose
- Reinstall the engine splash guard. Tighten to **25 Nm (18 lbf.ft.)**
- Reinstall the front skid plate. Tighten to **50 Nm (37 lbf.ft.)**
- Bend back the wheel arch lining. Install the small plate. Install the nuts. Tighten



- Press the wheel arch extension into place
- Take rivets from the kit. Rivet the front edge/lower edge of the wheel arch lining
- Reinstall the bumper panel
- Reinstall the wheel. Tighten the screws. Tighten to **140 Nm (103 lbf.ft)**.

50

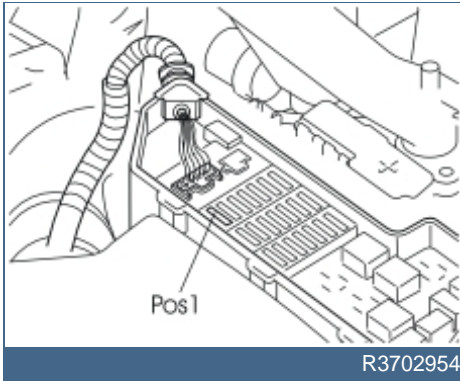

- Open the cover on the fuse holder in the engine compartment. Install a 25A fuse in position 1
- Reinstall the cover.

51

- Fill with coolant. Reinstall the expansion tank cap
- Reinstall the air cleaner (ACL). Connect any disconnected lines or hoses
- Reinstall the intake manifold on the front cover plate between the headlamps. Tighten the screws. Tighten to **10 Nm (7 lbf.ft)**
- Start the engine and bleed the cooling system
- Programme the software. See the service information in VIDA
- Test the function of the heater according to separate instructions.