



## XC90

Section	Group	Weight(Kg/Pounds)	Year	Month
3	39		2002	08

XC90 2003, XC90 2004

Replaces issue: 2002 05

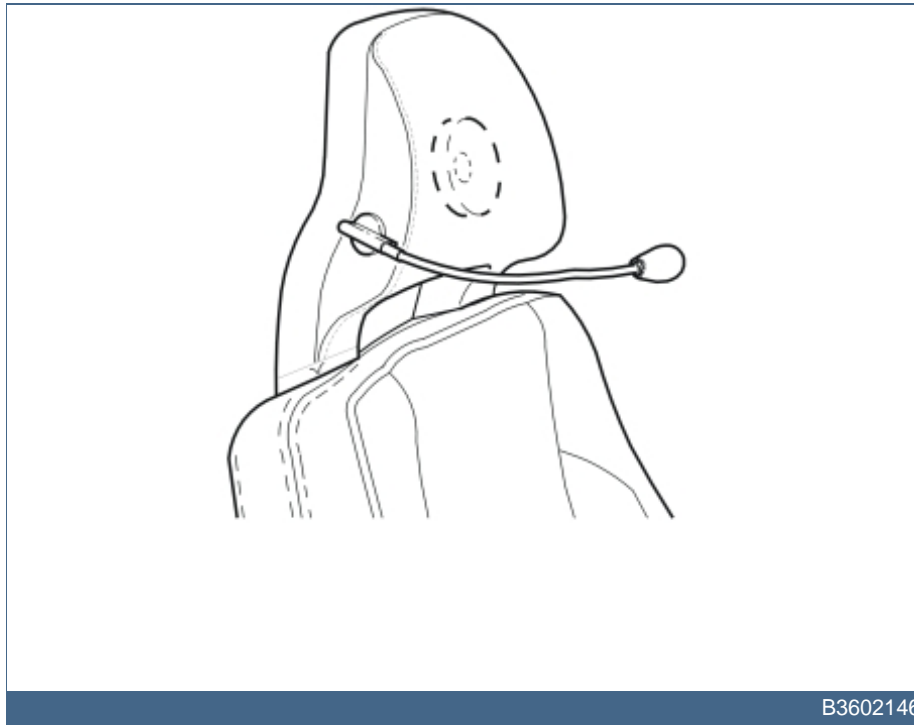

B3602146



## Required tools



A0000162



A0000163



A0801450

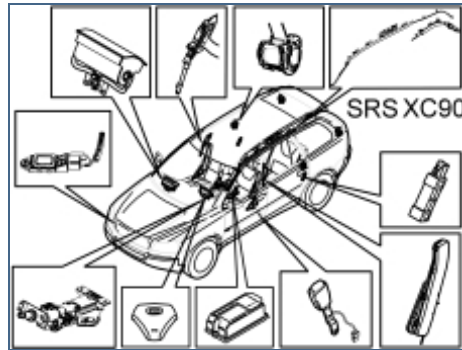

R8802817

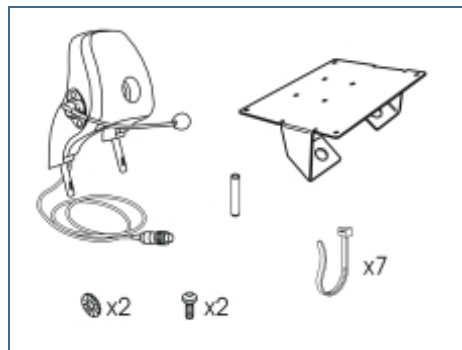

R3903808

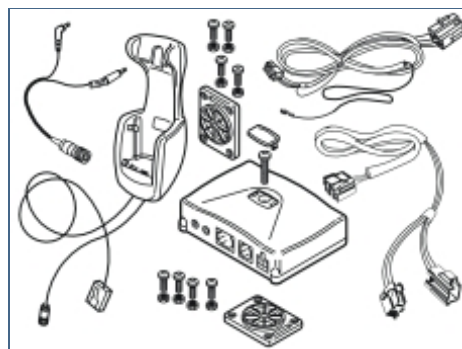

R3904093

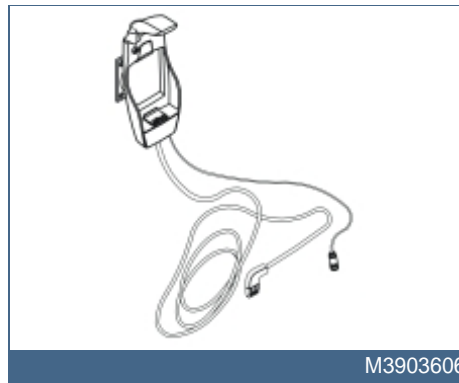
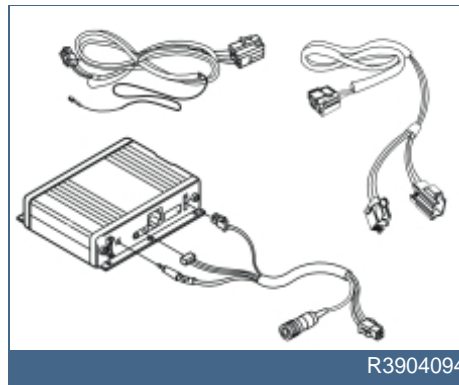
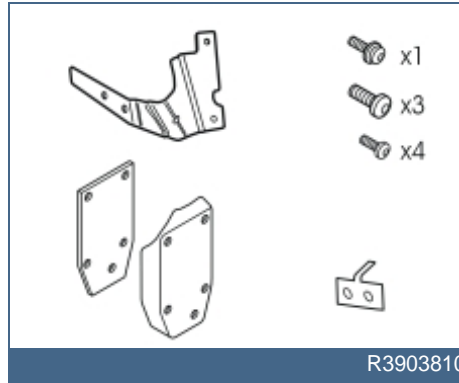



Any comments on this publication? Please contact your nearest dealer. Thank you!

Publication no: MA 8682160, Issue: 2002-08
Comments:..... ..... ..... ..... ..... ..... .....
From:.....
Address:.....
Telephone no:.....
Telefax:.....



## INTRODUCTION

- **NOTE! Read through the entire text before carrying out any work.**
- The front page gives the date of this edition and the edition it replaces
- The second page shows the tools needed for the installation and the contents of the installation kit
- The illustrations display the procedure in order of operation. The order of operation is repeated in the text section
- Cut out the text page in order to follow the illustrations and text at the same time.

## Cars equipped with SRS/SIPS (Airbag)

### Warning!

Extra care must be taken when working on cars equipped with SRS/SIPS air bags. This is important to prevent:

1. Personal injury
2. Damage to or malfunction of the SRS/SIPS system.

Work on the SRS/SIPS systems or related components must always be carried out by an authorised Volvo workshop.

## Is the car equipped with SRS (supplemental restraint system)?

Cars equipped with a driver's airbag have the letters "SRS" imprinted on the centre panel of the steering wheel. Cars equipped with driver's and passenger airbags are marked with "SRS" on both the steering wheel centre panel and also on the dashboard close to the airbag.

If the car is equipped with SIPS (side impact protection system ) a "SIPS" decal is marked on both the front seats.

Cars equipped with inflatable curtains have the marking "SRS" on one of the panels along the posts on the inside of the car.

Cars equipped with SRS (supplemental restraint system) also have a "SRS" decal on the front windscreen.

## Do not damage the SRS wiring!

Do not trap, fray, pierce or damage the SRS wiring. SRS wiring has orange casing and/or is plaited.

## Steering and front suspension

The contact reel in the SRS system can easily be damaged when working on the steering wheel, steering shaft or steering gear. Refer to the SRS (supplemental restraint system) Service Manual or service instructions in VIDA for information on carrying out such work. This is to prevent damage.

## SRS warning lamp

If the SRS warning lamp lights after repairs have been carried out, take the car to an authorised Volvo workshop.

## SRS collision sensor control module

### S60 / V70 (00-) / S80 / XC90

The collision sensor control module is located on the transmission tunnel



in the centre console, in front of the parking brake.

**WARNING!**

**The air bag inflation areas must not be obstructed. Never place any objects, such as upholstery or accessories, within these areas. The panels must be able to deploy in the correct manner at the right time otherwise there is a risk of personal injury in the event of a collision.**

**WARNING!**

**The ignition must be in position "0" and the key removed from the ignition if any connector in the SRS system is to be disassembled. Then wait at least one minute. Then disconnect the battery negative lead before disassembling any of the connectors. When work is completed the ignition key must be turned to position "II" before reconnecting the battery negative lead.**

**Handsfree**

**Note!**

This accessory is connected to the electrical system of the car. It requires software unique to the car.



1

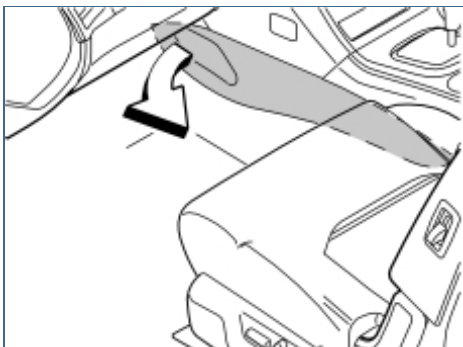

R8504165

## Preparations

- Remove the left and right-hand side panels from the centre console. Pull the panels free at the front edge and then backwards until all the clips have released.

2

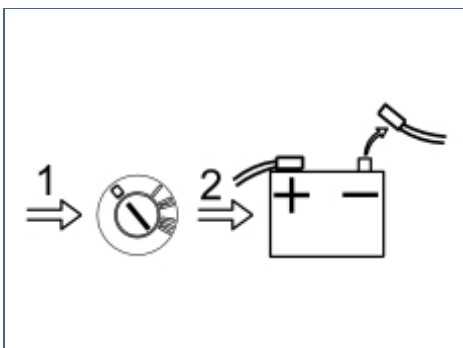

A8800136

## Preparations

### Applies to cars with power front seats

- Position the right-hand front seat so that the panels over the front and right rear seat mountings, and the small panel at the lower edge of the right-hand B-post are not obstructed. They will be removed later after disconnecting the battery negative lead

- Also position the left-hand front seat in a suitable position so that the hands free kit can be installed.

### Applies to all models

- Turn the ignition key to position 0
- Disconnect the battery negative lead.

### Note!

Wait at least five minutes before disassembling the connectors or removing other electrical equipment.



3A

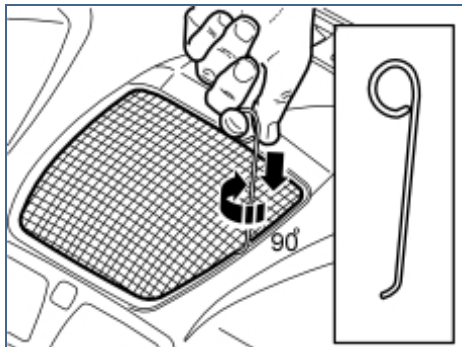

R8504166

## Preparations

### Illustration A

Remove the loudspeaker grille as follows:

- Take a length of **1.5 mm (1/16")** diameter welding rod. Bend one end to 90° (L=5 mm (13/64")). The other end is bent to form a handle
- Insert the first bent end down into the joint between the loudspeaker grille and the dashboard as illustrated, until it engages
- Twist the welding rod 90° so that the bent section engages with the underneath of the loudspeaker grille. It may be necessary to move the welding rod along the joint to twist the rod around.

3B

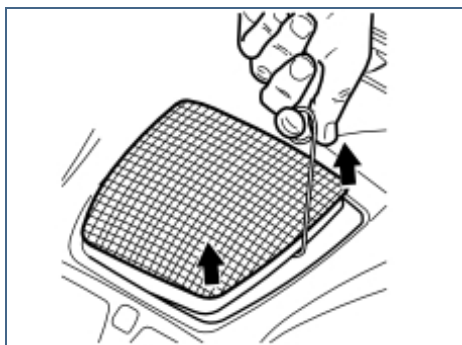

R8504167

### Illustration B

- Pull upwards until the loudspeaker grille detaches. The loudspeaker grille is securely fastened by four clips.

### Note!

Do not damage the dashboard.

- Place the loudspeaker grille to one side.

3C

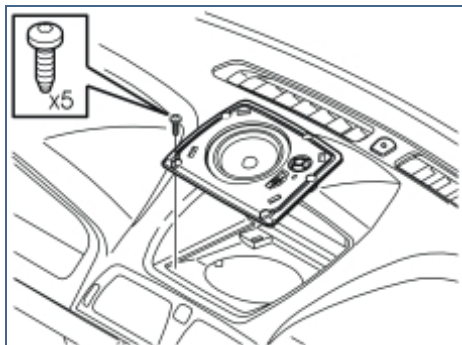

R3904127

### Illustration C applies to cars without a centrally-mounted loudspeaker

- Remove the bracket for the loudspeaker grille by removing the five screws and pulling it up out of the dashboard.

### Illustration D applies to cars with a centrally-mounted loudspeaker

- Remove the five screws in the loudspeaker. Pull up the loudspeaker slightly from the dashboard. Disconnect the connector.

3D

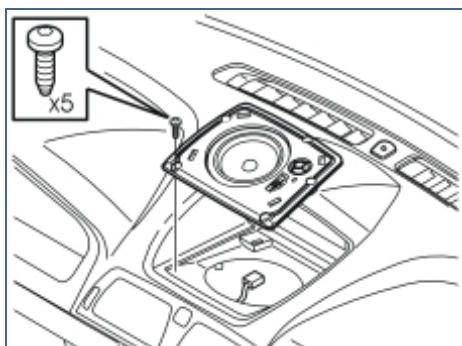

R3904128

### Illustration E applies to cars with RTI (road traffic information)

- Remove the five screws in the display for RTI (road traffic information). Pull up the display slightly from the dashboard. Disconnect the connectors. Disconnect the centrally-mounted loudspeaker connector if installed.





3E

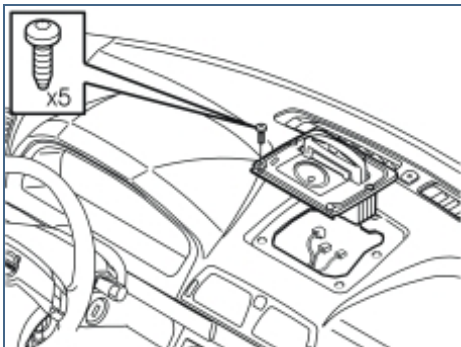

R3904129

4

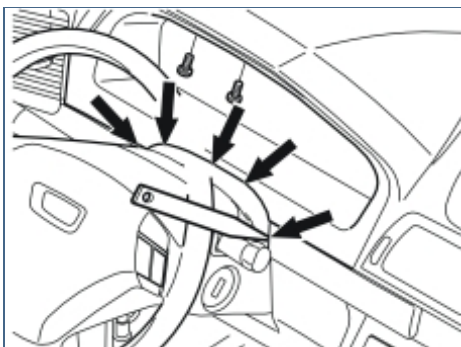

R3800878

## Preparations

- Lower the steering wheel to the lowermost position. Pull the steering wheel to the rearmost position
- Remove the two screws at the top edge of the combined instrument panel surround
- Carefully pry off the rubber seal from the upper steering column cover. Use a weatherstrip tool. It is secured with five clips
- Remove the surround by carefully pulling it backwards, first at the lower edge and then at the top edge until all the clips have released.

5

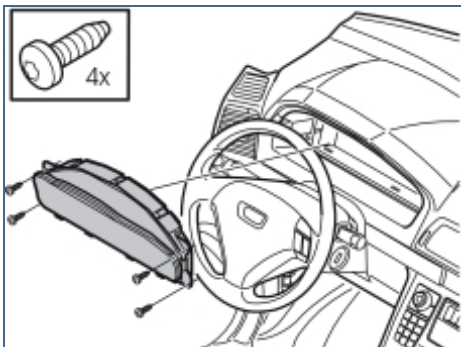

R3800876

## Preparations

- Remove the four screws for the combined instrument panel
- Pull out the combined instrument panel. Disconnect the connector on the reverse of the combined instrument panel.

6

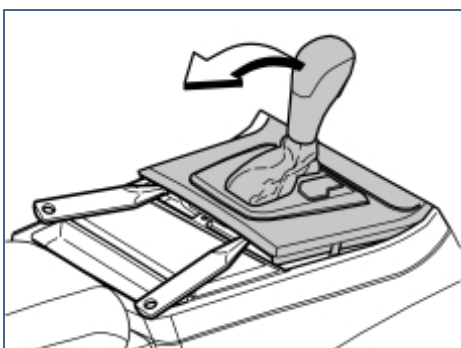

R8504113

## Preparations

- **Applies to cars with automatic gearboxes**
  - Turn the ignition key to position II.
- **Applies to all models**
  - Move the gear selector lever to its rearmost position
- Carefully pry off the gear selector lever panel at the lower edge using a weatherstrip tool. Pull the panel backwards to access the screws for the dashboard environment panel.



7

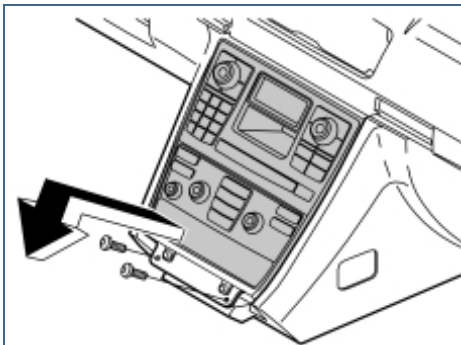

R8504051

## Preparations

- Remove the screws holding the bracket for the dashboard environment panel and the control module
- Pull out the bracket at the lower edge. Pull downwards from the top edge of the centre console
- Disconnect the connectors from the dashboard environment panel, control module. If applicable disconnect the CD player and/or Mini disc player connectors.

8

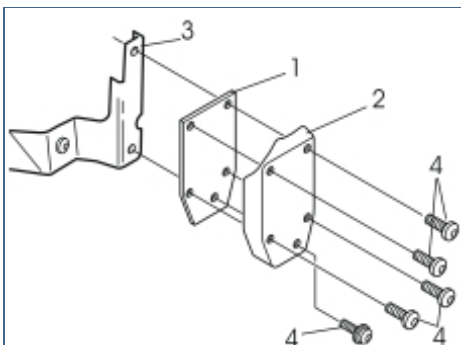

R3904206

## Installing the carphone holder

- Take the carphone holder bracket, the reinforcement panel, the cover and screws from the kit
- Install the reinforcement panel (1) and the cover (2) in the bracket (3) using the screws (4).

9A

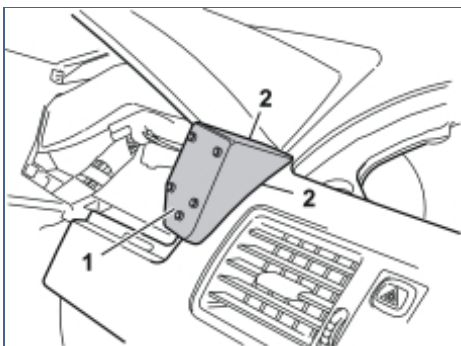

R3904204

## Installing the carphone holder

### Illustration A

- Position the entire unit (1) in the dashboard to mark out holes for the bracket. Adjust to achieve the optimum position. Do not press the unit hard against the dashboard, however, ensure that there are no gaps at the sides between the panel and the dashboard (2).

### Illustration B

- Hold the unit securely and mark out the holes through the bracket
- Drill out the two holes using a **5 mm (13/64")** diameter drill bit. Use a 25 mm (1") drill stop
- Remove any swarf
- Remove the cover and the reinforcement panel from the bracket.

9B

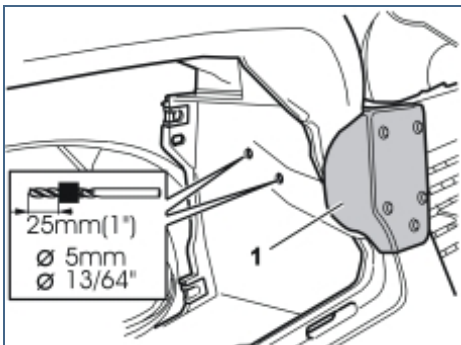

R3904205



10

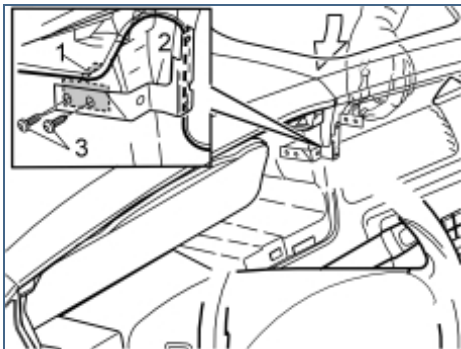

M8902743

## Installing the carphone holder

- Take the reinforcement panel (1) and the two screws from the kit
- Position the carphone holder wiring so that it is routed on the reverse of the bracket as illustrated
- Insert the reinforcement panel through the hole for the centre loudspeaker
- Install the bracket (2). Use the two screws (3). Tighten the bracket against the dashboard.

11

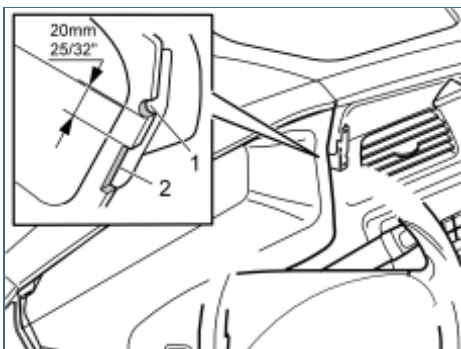

R8504494

## Installing the carphone holder

- Press the surround for the combined instrument panel into place
- Mark out the surround, following the sketch, where the cut-outs will be made for the wiring and the bracket for the handset holder
- Remove the surround. File out the groove (1) for the wiring for the handset. File the hole so that it is large enough for any excess wiring to be routed through the hole and hidden on the inside of the dashboard
- File out a groove (2) for the bracket for the handset holder
- Smooth off the edges of the groove.

12

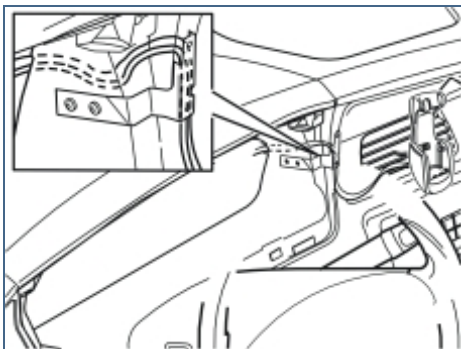

R3903766

## Installing the carphone holder

- Route the wiring to the carphone holder from the hole for combined instrument panel. Position the wiring at the left air duct in the centre console. Do not route more wiring than is required to secure the carphone holder
- Connect the combined instrument panel. Reinstall the combined instrument panel
- Reinstall the surround for the combined instrument panel. Tighten.

13

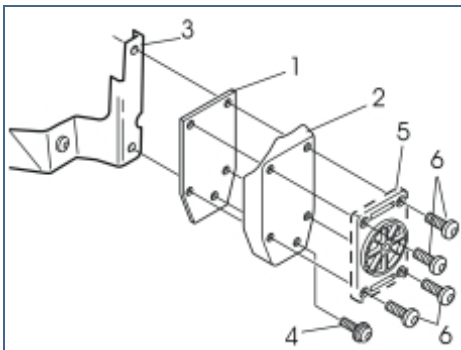

R3903763

## Installing the carphone holder

- Install the bracing plate (1) and the cover (2) in the bracket (3). Use the screw (4) (from the kit). Do not tighten fully yet
- Remove the mounting plate (5) for the carphone holder from the carphone holder. Tighten the mounting plate using the screws (6) from the kit
- Tighten the screw (4).



14A

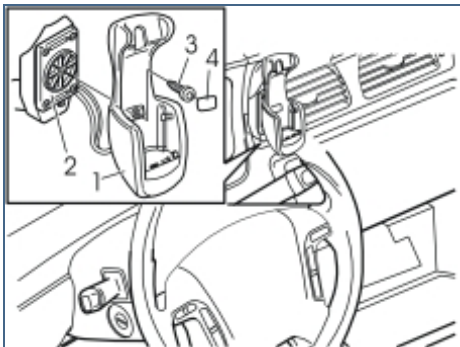

M3903001

## Installing the carphone holder

### Illustration A applies to Nokia

- Tighten the carphone holder (1) onto the mounting plate (2) using the screw (3)
- Install the cover (4).

### Illustration B applies to the Ericsson T28, T29 and T39

- Tighten the upper section of the carphone holder (1) onto the mounting plate (2) using the screw and washer (3)
- Press the lower section (4) of the carphone holder onto the upper section.

### Illustration C applies to the Ericsson T20

- Tighten the carphone holder mounting (1) onto the mounting plate (2) using the screw and washer (3)
- Press the carphone holder (4) onto the mounting.

14B

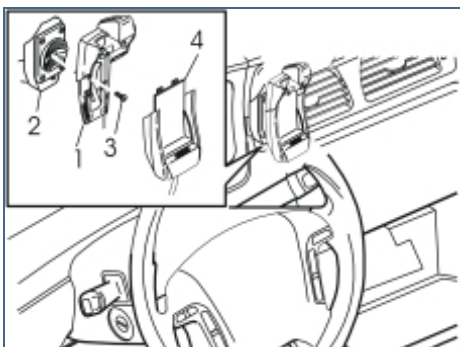

M3903171

14C

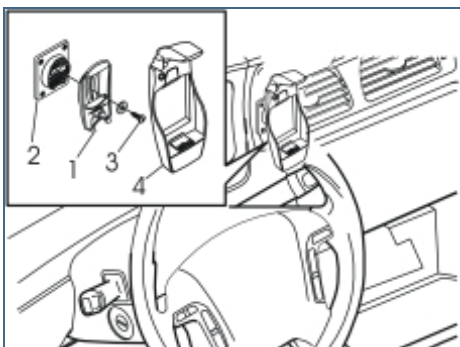

M3903607

## Installing the carphone holder

### Applies to Nokia

- Install the mounting plate (1) on the bracket. Use the screws and nuts from the kit.

15

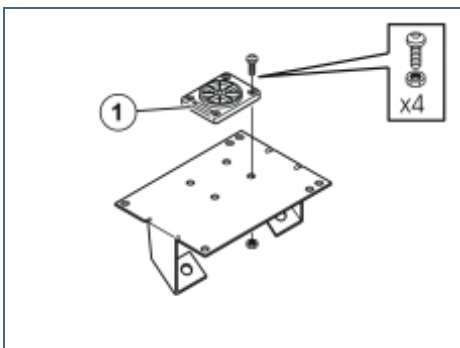

R3903813



16

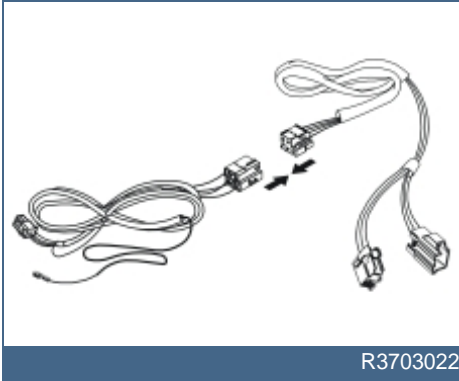

R3703022

## Installing the carphone holder

### Applies to all models

- Take the two large cable harnesses from the kit. Connect them to each other.

17A

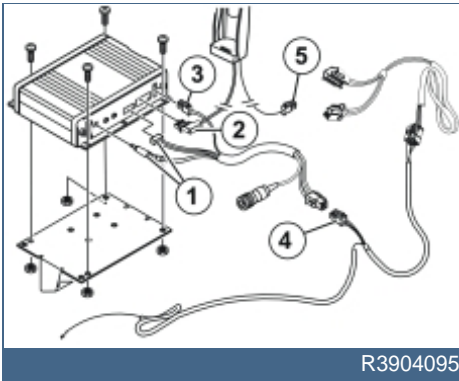

R3904095

## Installing the handsfree box

### Illustration A applies to Ericsson

- Take four screws and nuts from the kit. Tighten the handsfree box to the bracket
- Connect the wiring to the handsfree box as illustrated:
  - the wiring to the head restraint (1)
  - the wiring to the carphone holder (2)
  - the cable to the accessory electronic module (AEM) (3)
  - the joint cable (4) to the short cable for the handsfree box.

17B

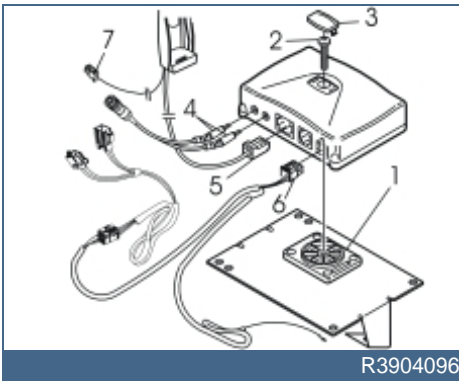

R3904096

### Illustration B applies to Nokia

- Tighten the handsfree box to the mounting plate (1) using the screw (2) from the kit
- Install the cover (3) over the screw
- Connect the wiring to the handsfree box as illustrated:
  - the wiring to the head restraint (4)
  - the cable to the carphone holder (5)
  - the cable to the accessory electronic module (AEM) (6).

### Applies to all models

- The remaining cable from the carphone holder, (5) in illustration A and (7) in illustration (B), is connected to the car aerial.



18A

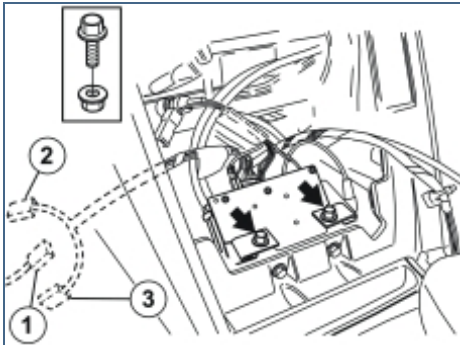

R3904318

## Installing the handsfree box

### Applies to all models:

- Take two screws and nuts from the kit. Install the bracket with the handsfree box on the existing bracket at the lower edge of the centre console.

### Note!

Ensure that the none of the wiring is trapped.

- Locate the grey (GR) pre-routed connector (1) for power supply. This comes from the heavy duty cable harness - either under the dashboard on the right-hand side of the steering column, immediately above the accelerator pedal (AP), or in the cut-out for the radio in the centre console.

The connector may be separate on the cable harness, or if the car has a MiniDisc player and / or CD player / changer, the connector may be on the junction cable for these components.

### Cars which do not have a pre-routed connector in the cut-out for the radio:

- Remove the soundproofing panel on the left-hand side. First remove the two screws, then pry off the soundproofing panel at the top edge (see illustration B).

### Applies to all models:

- Take the cable harness with the two grey (GR) connectors which was previously connected to the handsfree box. Pull it out through the left-hand side of the centre console to the existing connector
- Connect the pre-routed connector to the corresponding connector (2) on the routed cable harness
- Secure the excess connector (3). Also clamp the cable harness so that it is not in contact with any sharp edges and is not at risk of any other damage.

18B

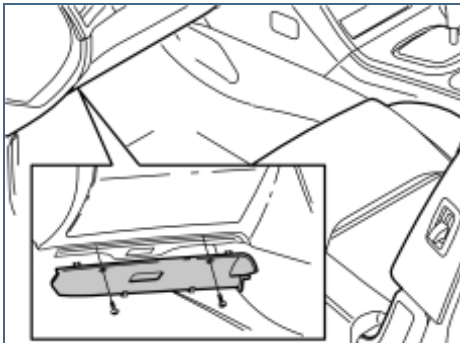

R8504495

19

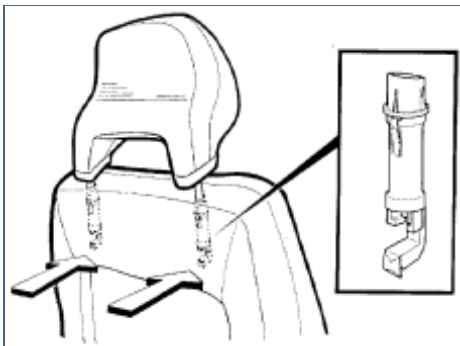

S3900558

## Head restraint preparations

- Remove the driver's seat head restraint. Press in the catches while pulling the head restraint up.



20

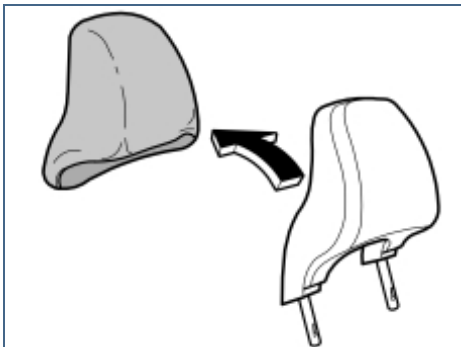

A3601074

## Head restraint preparations

### Does not apply to cars with leather upholstery

- Remove the upholstery from the head restraint. If the zip fastener catch is missing: Disconnect the clamps at the ends of the zip fastener. Pull the zip fastener apart.

21

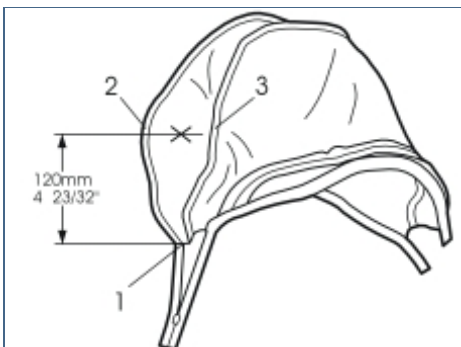

A3602219

## Head restraint preparations

### Does not apply to cars with leather upholstery

- Turn the head restraint upholstery inside out
- Mark up for holes on the right hand side of the head restraint. Mark from the underside (1) of the side 120 mm (4 23/32") upwards and mark out between the two seams (2) and (3).

22

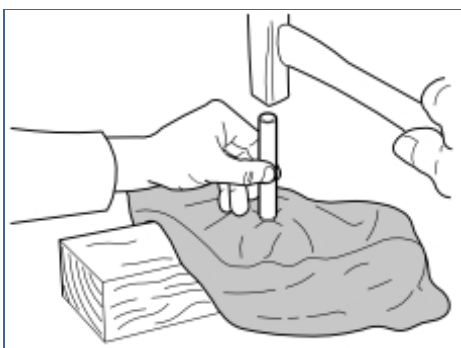

A3601076

## Head restraint preparations

### Does not apply to cars with leather upholstery

- Punch out the hole using the hole punch from the kit. Use a wooden or cork underlay
- Turn the upholstery the correct way
- Carefully pull the upholstery over the new head restraint with the microphone.

### Applies to cars with leather upholstery

- Take the new leather upholstery from the kit
- Carefully pull the upholstery over the new head restraint with the microphone.

23

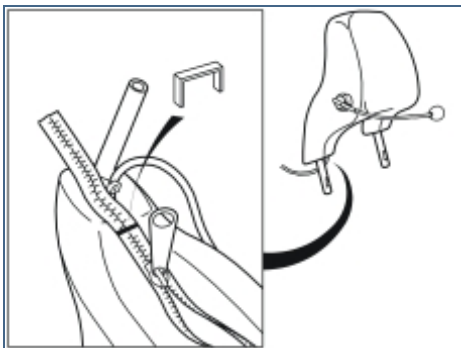

A3602218

## Head restraint preparations

- Close the zip fastener. If the zip fastener catch is missing, use a suitable zip fastener catch from the kit. Close the zip fastener again. Lock the ends using staples for example
- Push the ends of the zip fastener inside the upholstery.



24

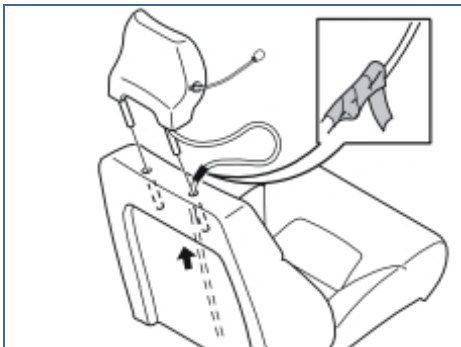

R3603009

## Installing the head restraint

- Insert a curtain wire from the bottom and upwards on the reverse of the backrest between the upholstery and the padding
- Tape the switch from the microphone cable to the curtain wire. Pull down through the seat
- Install the new head restraint.

25

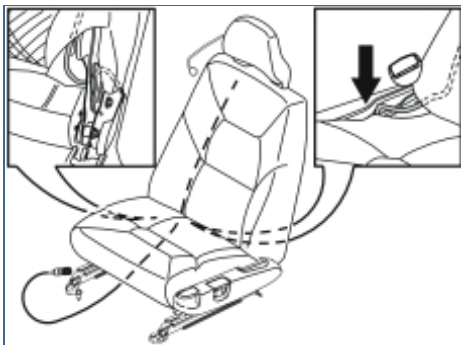

R3904099

## Installing the head restraint

- Pull up the cable from the head restraint. Position it under the upholstery and route it to the front of the backrest
- Lower the cable between the seat cushion and its panel and up to the joint in the carpet on the left-hand side of the centre console.

### Note!

Ensure that the cable does not come into contact with loose components or sharp edges.

26

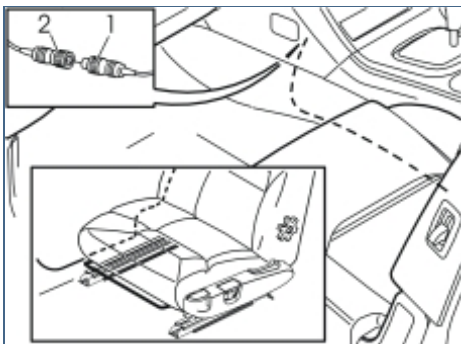

R3904098

## Installing the head restraint

- Pull the cable from the head restraint into the carpet joint inside the carpet. Pull it along the inside of the left-hand side of the tunnel console up to the centre console, along the air duct and up to the handsfree box that was installed earlier.

### Note!

Pull enough of the cable out of the carpet joint so that the seat can move between its limit positions without stretching or rubbing.

- Connect the connector (1) from the newly routed cable to the corresponding connector (2) for the handsfree box.

27

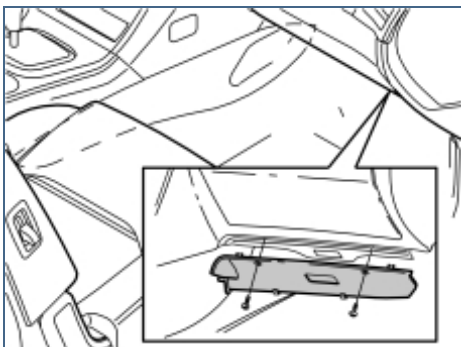

R8504419

## Cable routing to the accessory electronic module (AEM)

- Remove the right-hand side soundproofing panel. First remove the two screws. Then pry off the panel at the top edge.





28

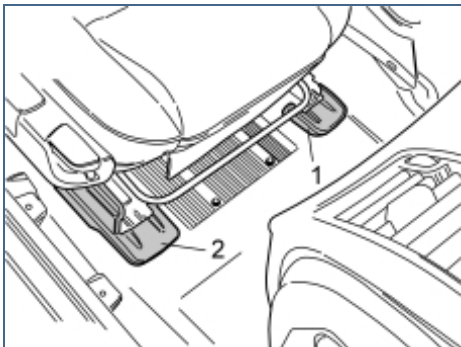

R8504168

## Cable routing to the accessory electronic module (AEM)

- Remove the cover (1) on the left front mounting on the right-hand front seat by prying off the front edge
- Pry off the front edge of the right panel (2). Remove the panel.

29

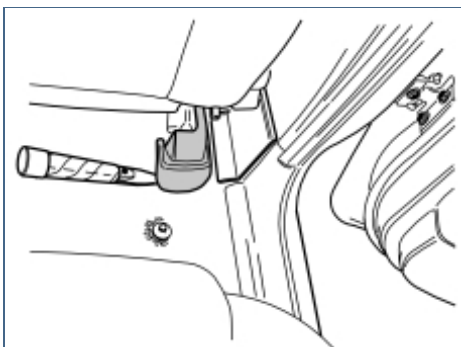

R8504241

## Cable routing to the accessory electronic module (AEM)

- Remove the panel on the right rear mounting on the right-hand front seat. Pry it up slightly at the rear edge and then pull it back / upwards.

30

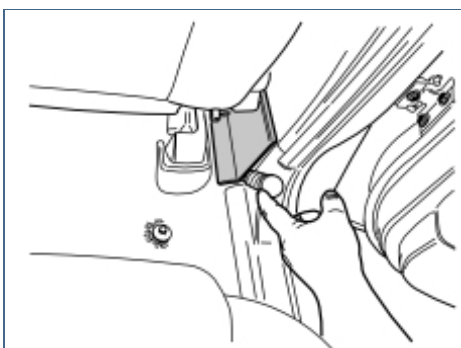

R8504169

## Cable routing to the accessory electronic module (AEM)

- Remove the panel over the joint between the door sills on the right-hand side. Carefully pry off the panel at the lower edge using a weatherstrip tool.

31

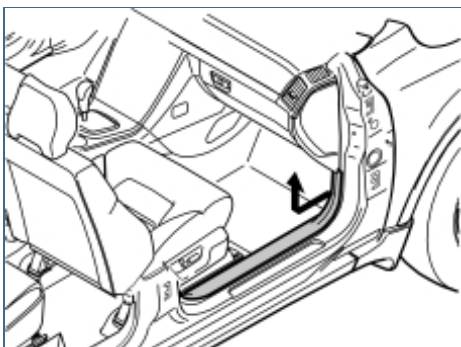

R8504170

## Cable routing to the accessory electronic module (AEM)

- Detach the sill trim panel for the right-hand front door. Pull off the panel starting at the front edge until the clip releases. Continue backwards until the remaining clips have released
- Unhook the sill trim panel from the B-post panel.



32

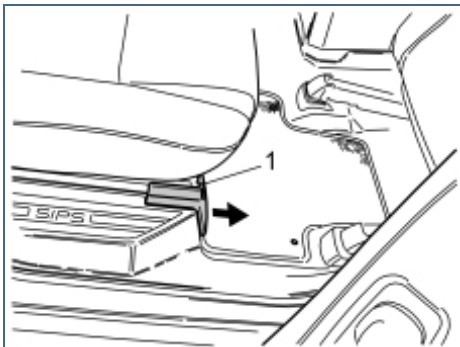

R8504171

## Cable routing to the accessory electronic module (AEM)

- Remove the panel in the right-hand front seat mounting on the right-hand seat in the second row. Push up the catch (1) on the top. Pull the panel forward.

33

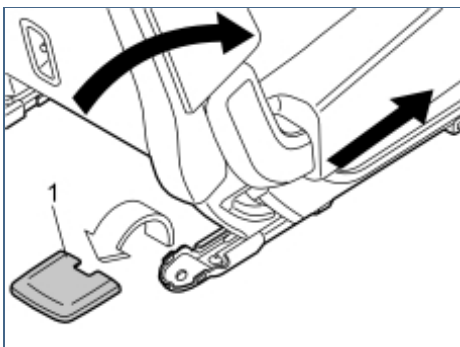

R8504172

## Cable routing to the accessory electronic module (AEM)

- Fold the backrest on the right-hand seat in the second row forward as far as possible. Slide the front seat forward as far as possible. (On cars with two rows of seats, the second row is secured.)
- Remove the cover (1) for the right rear seat mounting by prying off the rear edge.

34A

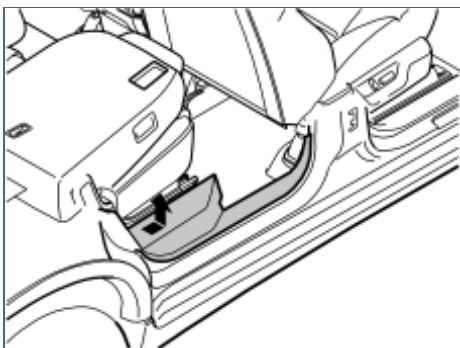

R8504173

## Cable routing to the accessory electronic module (AEM)

### Illustration A

- Remove the sill trim panel for the right-hand rear door. Pull the rear edge until the clips release. Continue forwards until the remaining clips have released.

### Applies to cars with two rows of seats

- On cars with two rows of seats the seat cannot be slid forwards. To remove the sill trim panel; Start by folding the backrest forward when pulling the rear edge of sill trim panel loose. Then reposition the backrest to raise the seat cushion and provide more room for removing the sill trim panel. It is securely positioned. Do not damage the panel and surrounding components.

34B

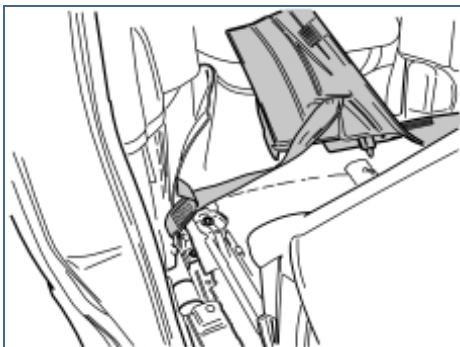

R8504174

### Illustration B

- Unhook the sill trim panel from the B-post panel. Position the panel in the second/third row of seats.



35

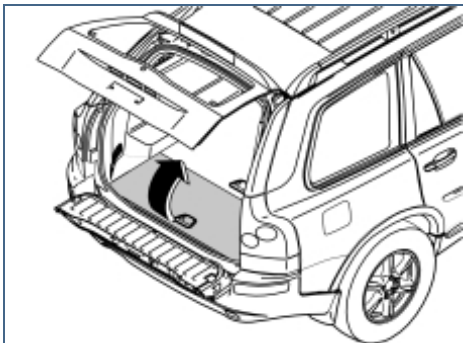

R8503999

## Cable routing to the accessory electronic module (AEM)

### Applies to cars with three rows of seats and integrated carrier bag holder on the underside of the centre floor hatch

- Fold the rear centre floor hatch up
- Detach the two straps from the panel underneath. Lift up the rear edge of the panel. Fold the floor hatch back towards the panel and lift out the floor hatch and the panel.

### Applies to cars with three rows of seats without integrated carrier bag holders

- Lift up the centre rear floor hatch at the rear edge and lift it out.

### Applies to cars with two rows of seats

- Remove the two centre floor hatches. First lift up slightly and then pull them loose from the mountings at the front edge. If the rear centre floor hatch has a carrier bag holder on the lower side, the floor hatch is secured by a strap on each of the shorter sides of the storage box. These must be removed.
- Remove the two storage boxes from underneath.

36

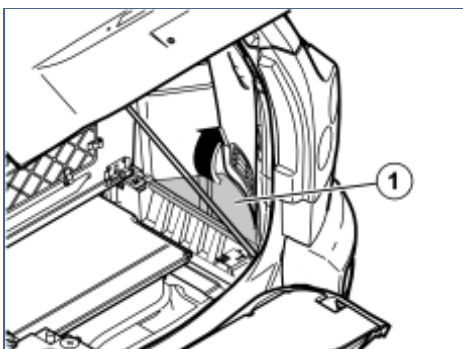

R8504158

## Cable routing to the accessory electronic module (AEM)

### Applies to all models

- Remove the right-hand side floor hatch (1).

37

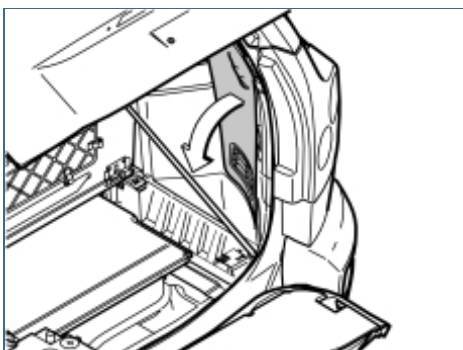

R8504159

## Cable routing to the accessory electronic module (AEM)

- Remove the folding side panel from the right-hand side in the cargo compartment.



38

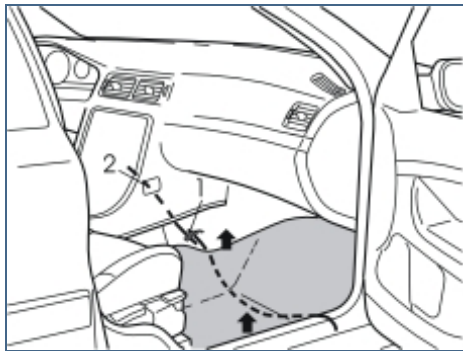

R3702905

## Cable routing to the accessory electronic module (AEM)

- Pull up the left and right sides of the carpet at the right-hand front seat slightly. Insert a wire (1) under the carpet at the front edge of the air ducts on the right-hand side of the centre console, and route it out at the right-hand door sill as illustrated
- Take the long cable harness (2) in the cable harness for the handsfree box. Route it up to the newly positioned wire. Tape the long cable harness to the wire
- Pull the cable harness out of the carpet at the right-hand door sill.

39

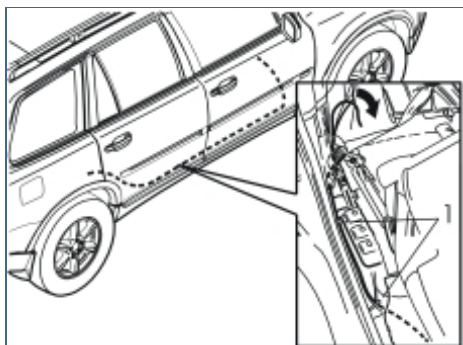

R3702904

## Cable routing to the accessory electronic module (AEM)

- Insert the cable harness between the carpet and the door sill towards the carpet as far as it will go. Route it along the right-hand side of the car up to the rear edge of the door opening for the right-hand rear door
- Pull the cable harness up to the right-hand front seat mounting on the right-hand seat in the second row of seats
- Pull away the carpet from the front edge of the right-hand side panel in the cargo compartment
- Route the cable harness along the right-hand side of the right-hand seat in the second row of seats towards the front edge of the rear wheel arch. Route it onwards on the left-hand side of the lower mounting for the seat belt, between the support bracket for the right-hand seat and wheel arch, and out at the left-hand side of the wheel arch
- Clamp the cable harness in the hole in the front member for the seat mounting and in the rear hole in the horizontal panel at the right-hand side of the seat. Use the tie straps (1) (from the kit).

40A

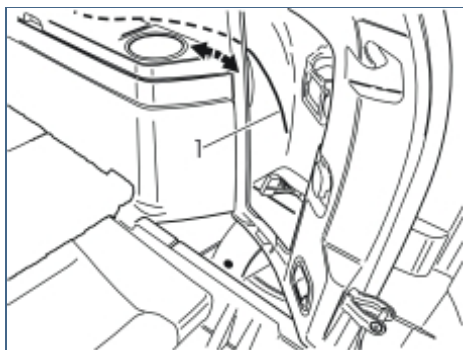

R3702907

## Cable routing to the accessory electronic module (AEM)

### Applies to cars with three rows of seats Illustration A

- Insert a cable (1) at the rear edge of the right-hand side panel and along the inside of the panel, above the mountings for the load securing eyelets and to the front edge of the side panel.

### Illustration B

- Tape the cable harness (2) to the wire and pull it out of the rear edge of the side panel.



40B



R3703023

41

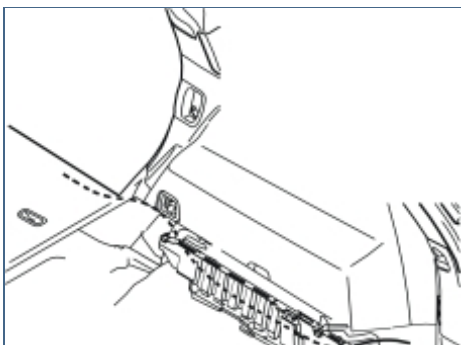

R3702935

## Cable routing to the accessory electronic module (AEM)

### Applies to cars with two rows of seats

- Route the cable on the left-hand side of the seat belt mounting at the front edge of the wheel arch, inside the carpet at the front edge of the side panel, between the side panel and the rear of the cargo floor support, to the accessory electronic module (AEM).

42

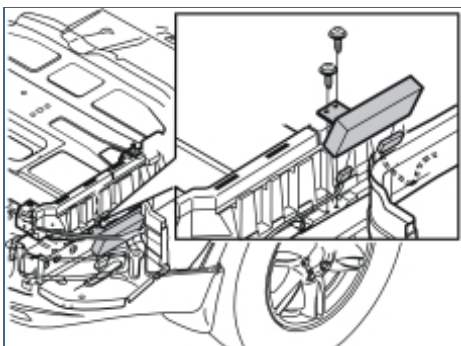

R3702881

## Connecting to the accessory electronic module (AEM)

- Remove the two screws from the bracket for the accessory electronic module (AEM) and lift up the entire unit. Cut off the tie straps if necessary.

43

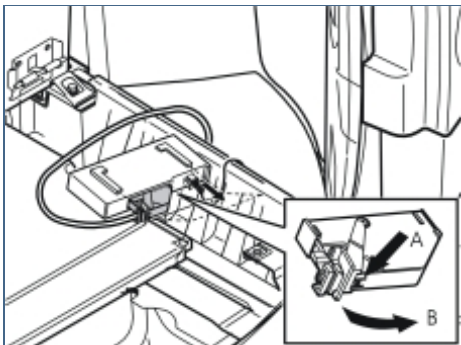

R3702909

## Connecting to the accessory electronic module (AEM)

- Disconnect the large connector from the accessory electronic module (AEM). First press in the catch (A). Pull the black locking handle (B) in the direction of the arrow until a click is heard. Disconnect the connector
- Disconnect the connector from the accessory electronic module.



44

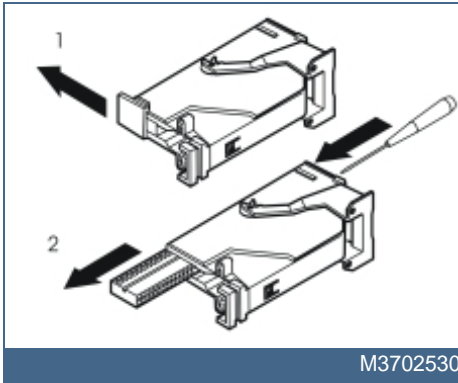

## Connecting to the accessory electronic module (AEM)

- Remove the black catch holding the black switch in place in the connector by pulling in the direction of the arrow
- Remove the black switch. Insert a pointed object in the hole on the other end of the connector. Press the switch out.

45

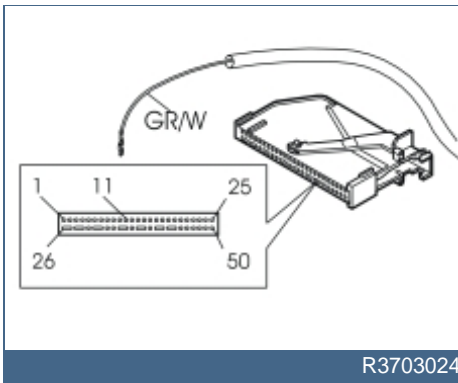

## Connecting to the accessory electronic module (AEM)

- Connect the Grey / White (GR/W) cable from the routed cable harness to terminal 11 (tele-mute) in the black connector for the accessory electronic module (AEM).

### Note!

The number markings can be found on the top and bottom of the black switch. However, the markings are extremely small so be careful when installing the two cables.

- Reinstall the black switch in the connector. Lock into place using the catch
- Press the connector into the Accessory Electronic module. Secure using the black locking handle
- Reinstall the accessory electronic module (AEM) with the bracket and clamp the wiring with the tie strap from the kit.

### Note!

If the car is equipped with the accessory windscreen aerial, it should be installed at this stage before the components on the right-hand side of the car are reinstalled.

46

## Connecting to the accessory electronic module (AEM)

- Reinstall the folding panel on the right-hand side in the cargo compartment
- Reinstall the right-hand side floor hatch
- Reinstall the carpet at the front edge of the right-hand side panel
- Reinstall the sill trim panel in the right-hand rear door
- Reinstall the cover(s) over the seat mountings on the second row of seats.



47

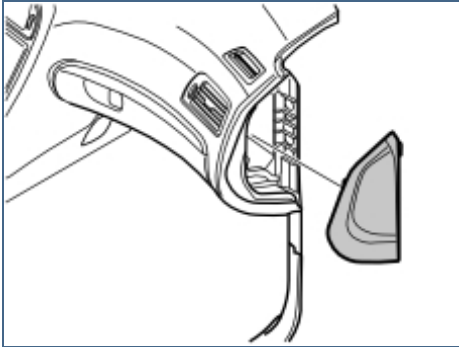

M8502816

## Installing the integral aerial

- Remove the panel on the right end of the dashboard.

48

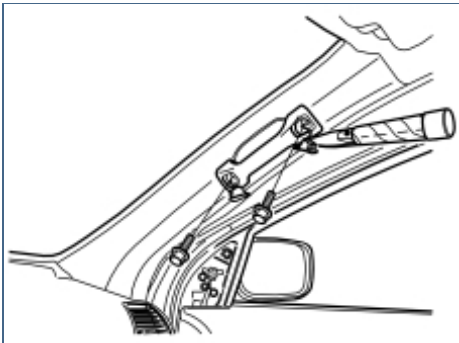

R8504175

## Installing the integral aerial

- Pry off the cover on the grab handle in the right-hand front door. Remove the screws.

49

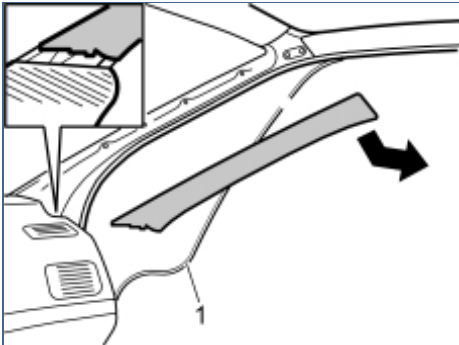

R8504163

## Installing the integral aerial

- Remove the rubber strip (1) at the front edge of the right-hand front door
- Remove the right-hand A-post panel by carefully pulling the top edge of the panel outwards until the clip on the inside releases. Pull up from the mounting in the dashboard.

### Note!

Do not damage the headlining.

50

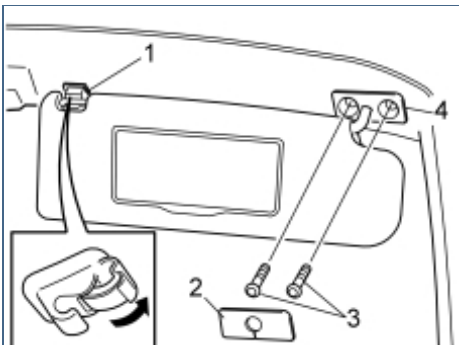

R8504176

## Installing the integral aerial

- Remove the sun visor from the inner mounting (1) on the right-hand side
- Carefully pry the cover (2) off. Remove the two screws (3) for the sun visor mounting
- Remove the inner mounting (1) by first prying up the catch as illustrated. Then insert a small screwdriver in the rear edge of the exposed hole and press the sprung catch forward to release it from the hole in the roof. At the same time pull the rear edge of the mounting downward/backwards so that the catch at the front edge and both catches at the sides release.

### Note!

Do not damage the headlining.



51

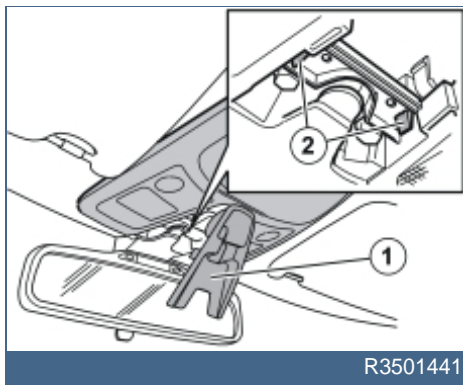

## Installing the integral aerial

- Fold down the cover (1) by carefully pulling down the front edge of the cover
- Squeeze the catches (2). Pull the front edge of the panel downwards. Then pull the rear edge off.

52

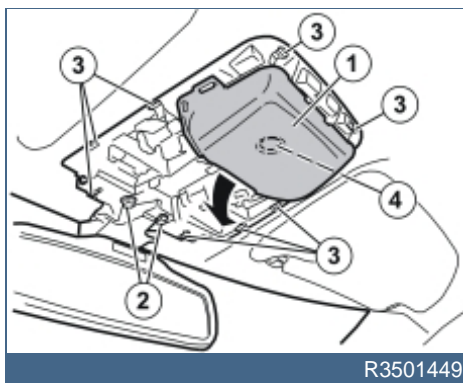

## Installing the integral aerial

- Remove the rear view mirror and the front interior lighting (1). First remove the two screws (2) and then press in the eight catches (3) around the interior lighting
- Carefully pull the components downwards and allow them to hang by their wiring. (The interior lighting is secured to the roof using the clip (4).)

53

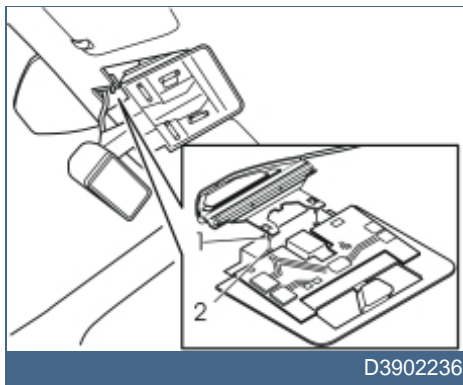

## Installing the integral aerial

- Install the new aerial. Carefully bend the headlining downward and slide the aerial backward and inwards. Align the aerial lugs (1) with the grooves in the bracket (2)
- Insert the cable at the inside of the front edge of the headlining. Route the cable out towards the right-hand A-post
- Secure the cable using butyl tape
- Reinstall the bracket and rear view mirror. Tighten the screws. Tighten to **10 Nm (7.5 lbf. ft.)**
- Reinstall the panel. Securely lock the panel using the cover.

54

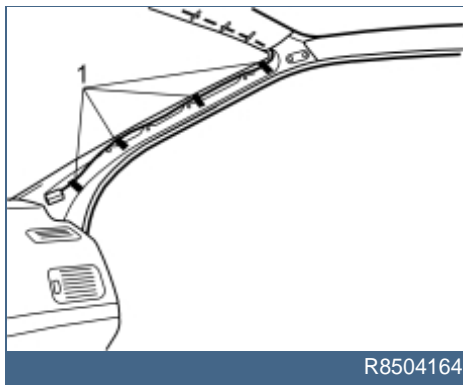

## Installing the integral aerial

- Route the cable down from the headlining along the right A-post
- Tape the cable onto the existing cable harness as illustrated (1).

### Warning!

Ensure that the cable is not routed over the inflatable curtain. This could compromise the function of the inflatable curtain in the event of an accident.





55

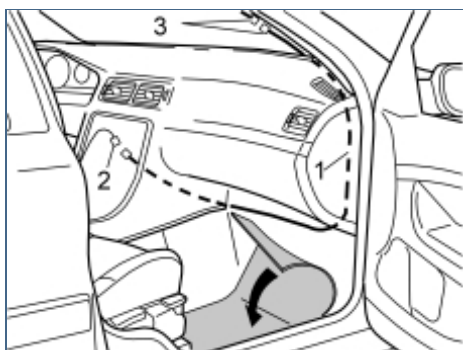

M8503790

## Installing the integral aerial

- Push the carpet to one side by the right-hand front seat
- Take the extension cable (1) from the kit. Route the cable between the A-post and the right-hand side of the dashboard, continue along the right-hand end to the front edge of the floor
- Route the cable to the left along the front edge of the floor and up to the inside of the centre console
- Connect the cable (1) to the corresponding cable (2) from the hands free box
- Connect both connectors (3) at the right A-post to each other
- Wrap the foam tape around the connectors to prevent rattling.

56

## Installing the integral aerial

- Reinstall the A post panel. Tighten the grab handle. Tighten to **10 Nm (7.5 lbf. ft.)**. Reinstall the cover
- Reinstall the rubber strip in the right-hand front door
- Reinstall the panel on the end of the dashboard
- Reinstall the sun visor. Tighten the screws. Tighten to **10 Nm (7.5 lbf. ft.)**. Reinstall the cover and the inner mounting
- Fold the carpet on the right-hand side back into place
- Reinstall the panel on the door trim for the right-hand front door. Press the B-post lower panel into place
- Reinstall the soundproofing panel on the right and left-hand sides
- Reinstall the cover and panel on the right-hand front seat
- Connect the connectors to the dashboard environment panel and control module. If applicable connect the CD player and/or Mini disc player connectors
- Position the bracket. Tighten the bracket using the two screws. Reinstall the gear selector lever panel
- Reinstall (depending on the equipment of the car):
  - the display for the RTI and the centre loudspeaker if applicable
  - the centre loudspeaker
  - the bracket for the loudspeaker grille



the loudspeaker grille.

57

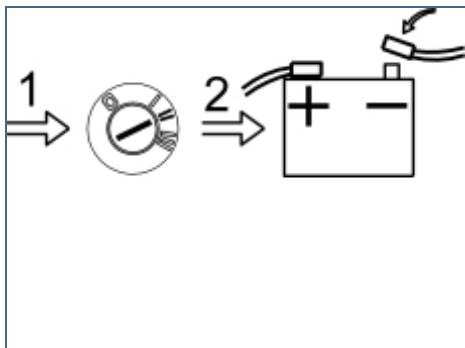

A8800137

## Installing the integral aerial

- Turn the ignition key to position II
- Reconnect the battery negative lead
- Reinstall the storage boxes and floor hatch(es)
- Reinstall both the side panels on the centre console
- Program the software using VCT2000 according to the service information in VIDA.