

XC90 2003 B6294T, XC90 2004 B6294T, XC90 2005 B6294T, XC90 2006 B6294T

B6294T

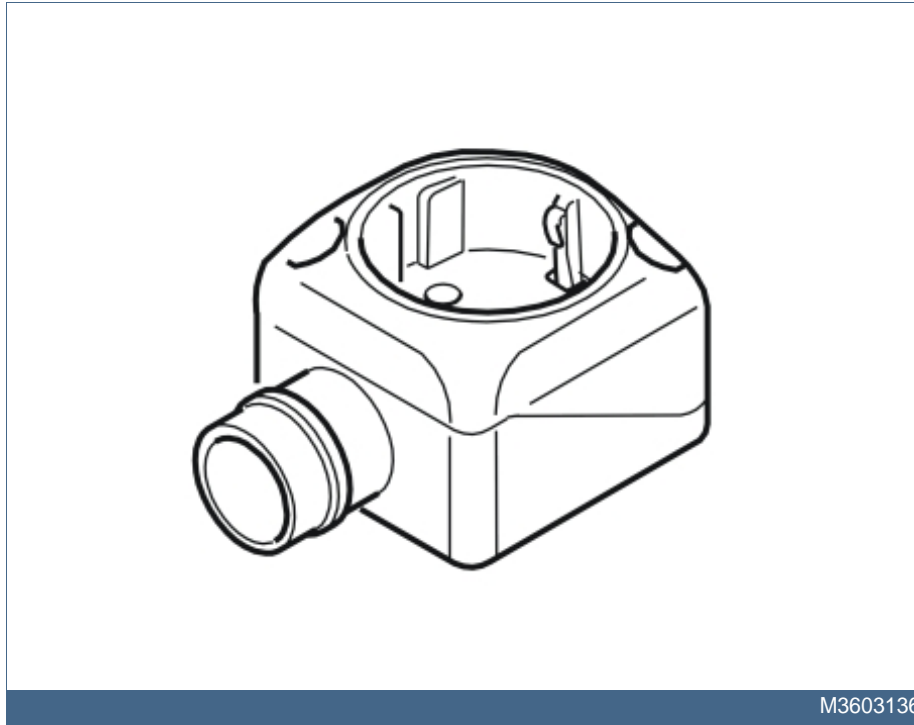

M3603136

Required tools



A0000162



Nm  
lbf.ft

A0000161

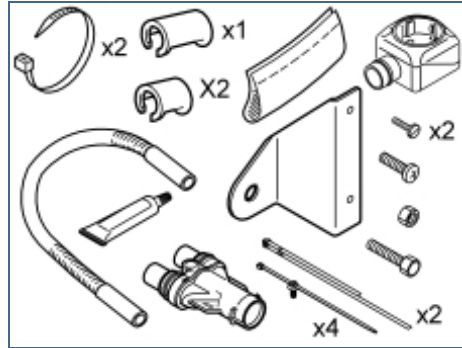

R8703948

Any comments on this publication? Please contact your nearest dealer. Thank you!

Publication no: MA 30664491, Issue: 2003-04
Comments:..... ..... ..... ..... ..... .....
From:.....
Address:.....
Telephone no:.....
Telefax:.....

## INTRODUCTION

## Passenger compartment socket 230V, B6294T

- **NOTE! Read through the entire text before carrying out any work.**
- The front page gives the date of this edition and the edition it replaces
- The second page shows the tools needed for the installation and the contents of the installation kit
- The illustrations display the procedure in order of operation. The order of operation is repeated in the text section
- Cut out the text page in order to follow the illustrations and text at the same time.

1

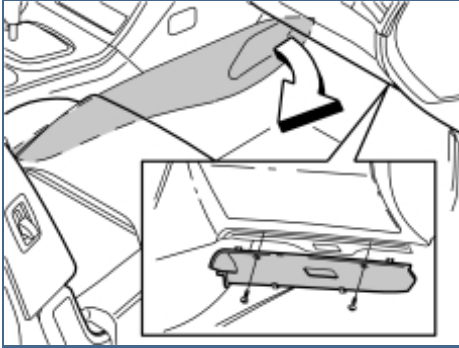

R8504142

- Remove the right-hand side panel from the centre console. Pull off the panel at the front edge. Then continue backwards until all the clips release
- Remove the right-hand side soundproofing panel. First remove the two screws. Then pry off the panel at the top edge.

2

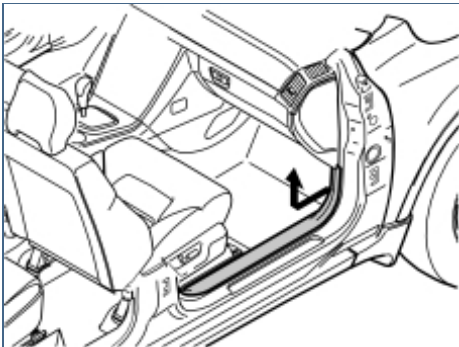

R8504170

- Remove the sill trim panel for the right-hand front door. Pull the front edge until the clip releases. Then continue backwards until the remaining clips have released
- Pull away the front edge to the right to access the edge of the carpet.

3

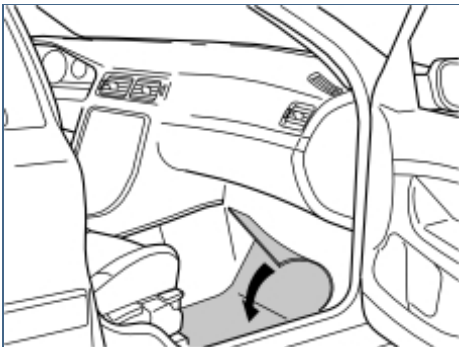

R8703677

- Fold the carpet to one side by the right-hand front seat.

4

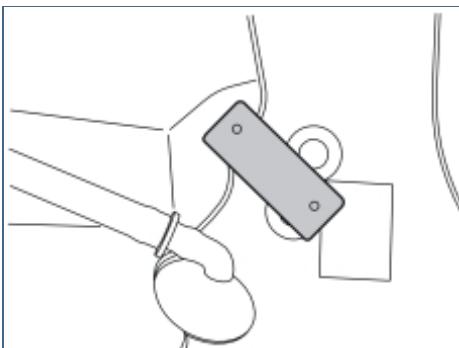

M3603196

- Remove the lower piece of tape. The tape is situated where the bracket is to be screwed into place
- Take the bracket and screw from the kit. Install the bracket in the existing weld nut under the recently removed piece of tape
- Turn the bracket so that it is positioned as illustrated
- Loosely install the connector. Check that the connector is straight, with the power connector at the front
- Tighten the bracket. Tighten to **10 Nm (7 lbf. ft.)**
- If the car has a child seat mounting bracket, the passenger compartment socket bracket must be positioned above this. Secure using the M6 screw. Tighten to

10 Nm (7 lbf. ft.).

5

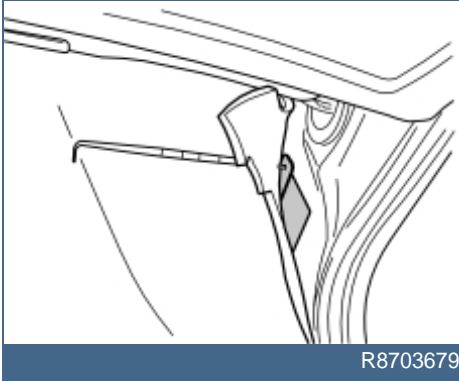

- Fold the carpet back over the bracket
- Make a hole in the carpet opposite the upper mounting hole in the bracket using a double ended scribe.

6

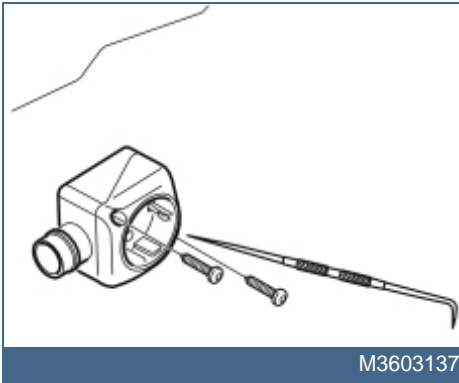

- Take the passenger compartment socket and a screw from the kit. Tighten the passenger compartment socket to the bracket in the upper mounting
- Insert the double ended scribe into the lower mounting for the passenger compartment socket. Make a hole in the carpet opposite the lower hole on the bracket
- Tighten the lower mounting for the passenger compartment connector socket using a screw from the kit.

7

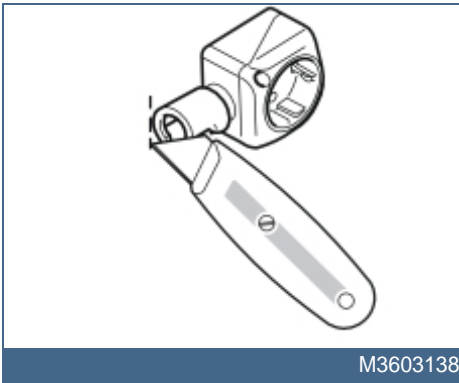

- Press a locking sleeve (from the kit) onto the passenger compartment socket. Slide the locking sleeve as far along the terminal for the passenger compartment socket as possible
- Take a carpet knife and cut a slit in the carpet just in front of the locking sleeve. The cut must be as long as the diameter of the locking sleeve.

**Note!**

Do not damage wiring or hoses under the carpet.

- Remove the passenger compartment socket from the bracket.

8

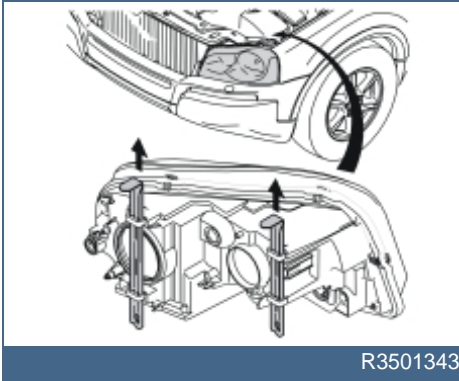

R3501343

- Remove the left-hand headlamp by pulling up the two cotter pins and then carefully pulling the headlamp forwards.

9

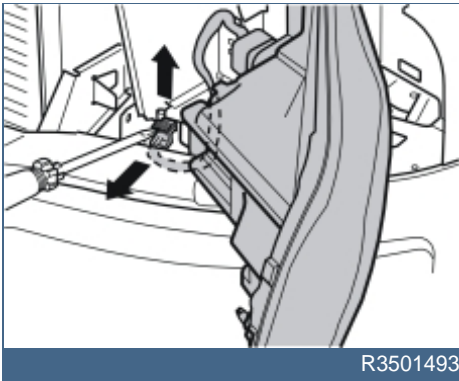

R3501493

- Carefully pry up the catch on the headlamp connector using a screwdriver
- Pull up the lock completely. Disconnect the connector. Place the headlamp to one side.

10

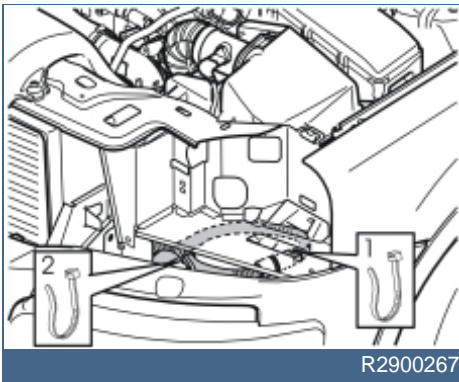

R2900267

**Applies to cars with an engine block heater**

- Remove the two tie straps that hold the cable to the front engine block heater socket. Route the cable.

11

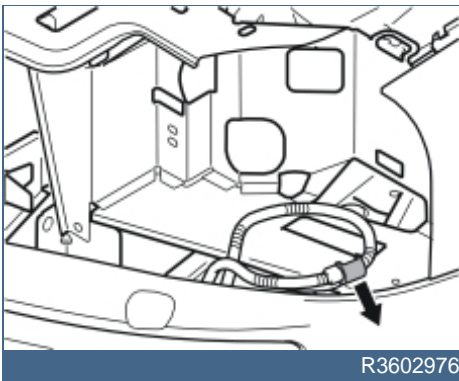

R3602976

**Applies to cars with an engine block heater**

- Remove the locking sleeve over the joint on the wiring for the engine block heater. Disconnect the wiring from each other.

12

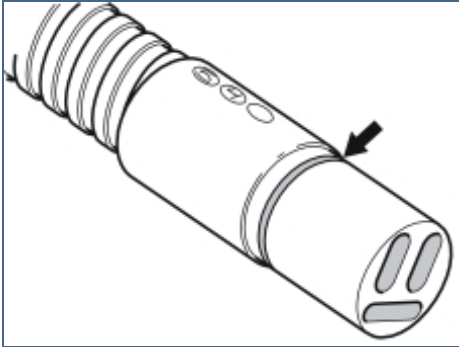

D3601932

- Take a junction connector from the kit. Grease the O-ring using low temperature grease (P/N 1161417-9). Grease the O-ring on the connector for the front engine block heater socket.

**Note!**

Do not get any grease on the contact surfaces of the connector.

13

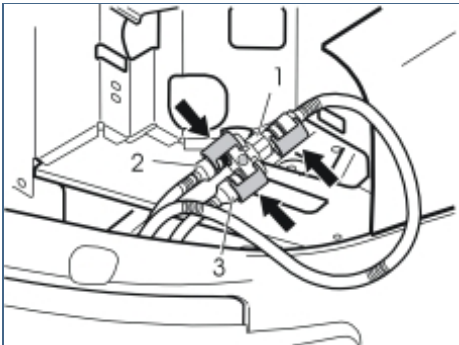

R3602939

- Take the long cable for the passenger compartment socket from the kit. Route it down the left-hand side of the left side member
- Connect the front engine block heater socket cable to socket (1) on the junction connector
- Connect the wiring for the engine block heater and passenger compartment connector socket to either socket (2) or (3) on the junction cable
- Press the three locking sleeves (from the kit) over the cable splices. The larger locking sleeve must be on the socket (1).

14

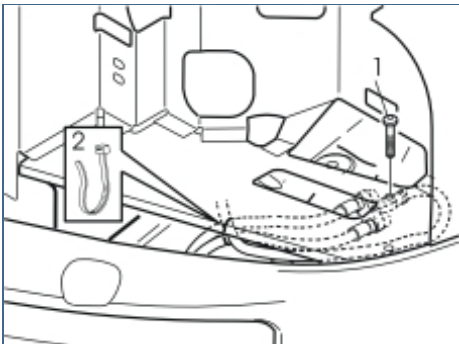

R2900268

- Position the junction connector with the wiring on the underneath of the plate under the headlamp, with the two sockets pointing forward and the cable from the front engine block heater socket pointing backward
- Take the screw and the nut from the kit. Tighten the junction connector in the hole in the plate (1)
- Take a tie strap from the kit and secure the wiring at point (2)
- Connect the connector to the headlamp and reinstall it.

15

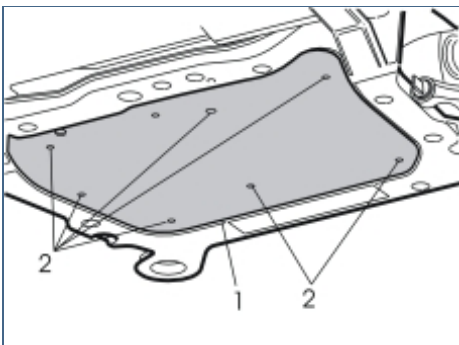

R2000348

- Remove the engine splash guard (1) by removing the screws (2).

16

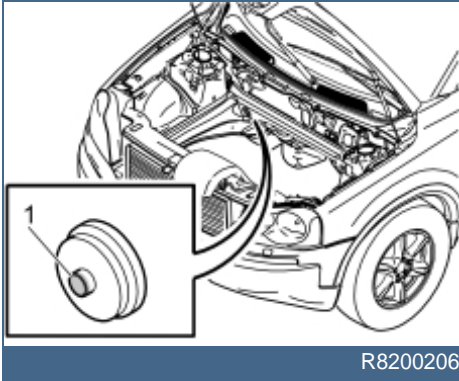

R8200206

- Press out the pre-punched engine compartment insulation
- Remove the rubber grommet (1) from the cowl panel and cut off the top.

17

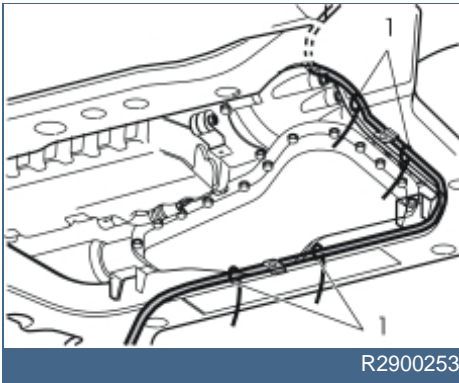

R2900253

- Route the cable for the passenger compartment socket over the left front corner of the sub-frame, where the cable to the engine block heater runs
- Press four tie straps (1) from the kit onto the holes in the sub-frame. Position the cable in the clamps but do not tighten them yet.

18A

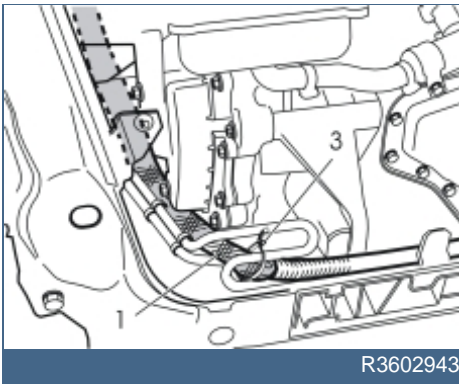

R3602943

#### Illustration A

- Take the insulation (1) from the kit. Thread it onto the cable
- Take the rubber grommet from the kit. Thread the cable through it
- Route the cable into the passenger compartment as illustrated
- Adjust the length of the cable to the rubber grommet.

#### Illustration B

- Pull back the cable leaving the insulation in position. Secure the upper end of the insulation. Use the two tie straps (2) from the kit
- Grease the side of the rubber grommet facing inwards into the passenger compartment. Use low-temperature grease
- Route the cable into the passenger compartment. Carefully pull the rubber grommet into position from inside the passenger compartment by pulling the cable for the passenger compartment connector socket.

#### Illustration A

- Clamp the cable at the servo pipe using a tie strap (3) from the kit
- Adjust the cable in the four tie straps in point and tighten them.

18B

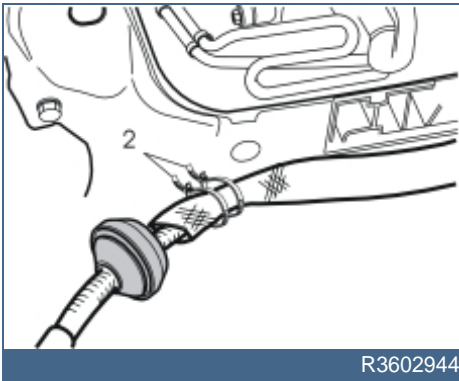

R3602944



- Reinstall the engine splash guard. Tighten the screws. Tighten to **25 Nm (17 lbf. ft)**.

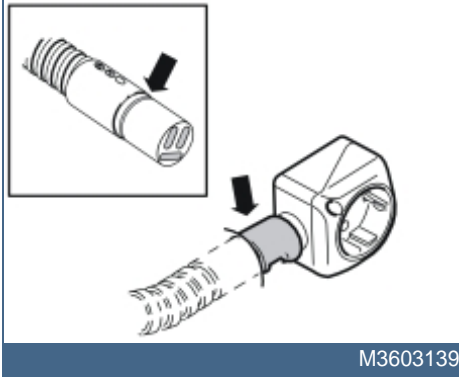

- Insert the cable from the engine compartment through the hole in the carpet
- Grease the O-ring using low temperature grease, (P/N 1161417-9).

**Note!**

Ensure that no grease gets onto the connector surfaces.

- Connect the cable to the passenger compartment connector socket. Press a locking sleeve (from the kit) over the joint
- Fold the carpet back into position and install the passenger compartment socket using both the screws.

**Reinstall:**

- the soundproofing panel
- the sill trim panel
- the right side panel for the centre console.