



## S80 (-06) / XC90

Section	Group	Weight(Kg/Pounds)	Year	Month
8	87		2003	10

S80 (-06) 2002, S80 (-06) 2003, S80 (-06) 2004, S80 (-06) 2005, S80 (-06) 2006, XC90 2003, XC90 2004, XC90 2005, XC90 2006, XC90 2007, XC90 2008

# Installation instructions, accessories - Relay EPH

Volvo Car Corporation Göteborg, Sweden



## Required tools



A0000162



A0000163



Nm  
lbf.ft

A0000161



A0801178

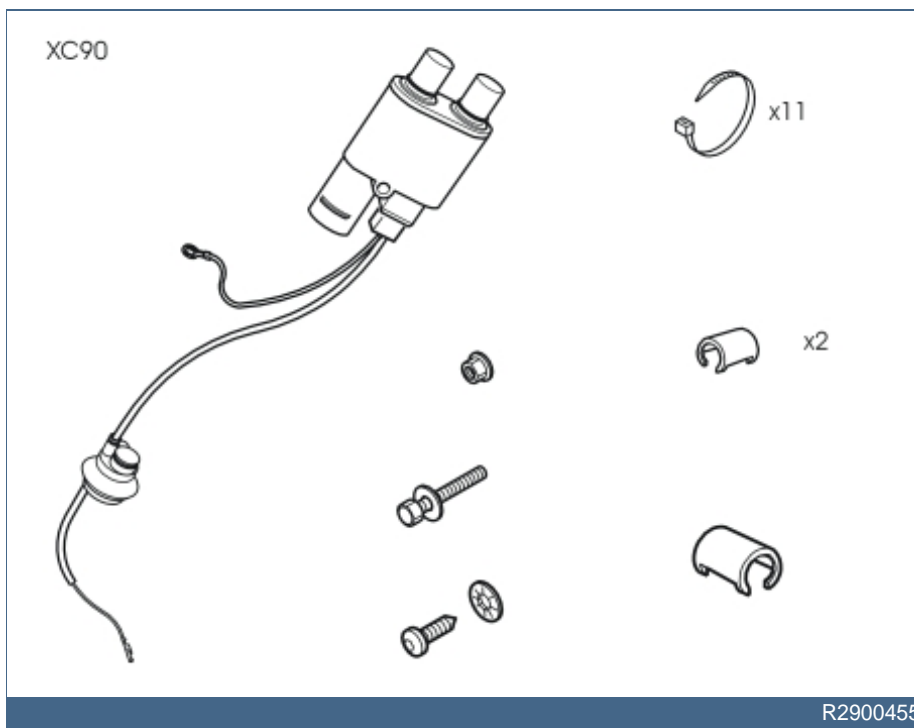
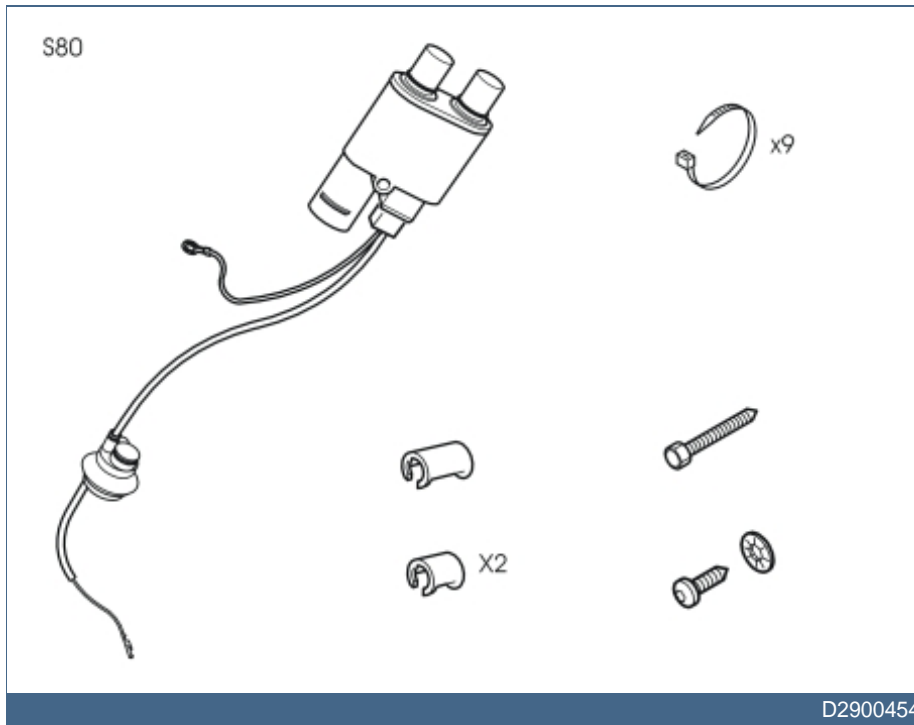



Any comments on this publication? Please contact your nearest dealer. Thank you!

Publication no: MA 30664939, Issue: 2003-10
Comments:..... ..... ..... ..... ..... ..... .....
From:.....
Address:.....
Telephone no:.....
Telefax:.....



## INTRODUCTION

## Relay EPH

- **NOTE! Read through the entire text before carrying out any work.**
- The front page gives the date of this edition and the edition it replaces
- The second page shows the tools needed for the installation and the contents of the installation kit
- The illustrations display the procedure in order of operation. The order of operation is repeated in the text section
- Cut out the text page in order to follow the illustrations and text at the same time.



1

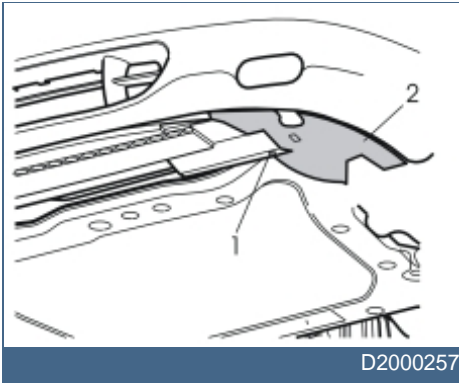

**Point - applies to the S80**

- Raise the car
- Remove the screw (1) from the left air baffle (2) for the front brake
- Pull the left air baffle backwards. Remove the left air baffle
- Remove the right air baffle in the same way.

2

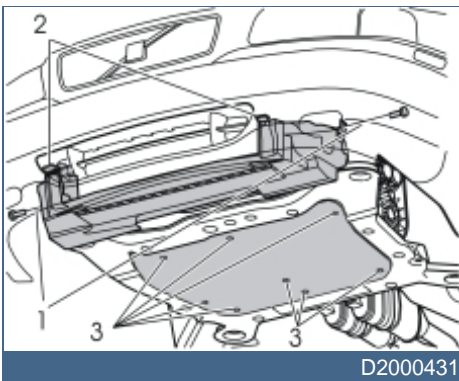

**Point - applies to the S80**

- Remove the screws (1)
- Press in the catches (2) and pull the air baffle down/backwards. Remove the air baffle
- Remove the screws (3). Remove the splash guard.

3

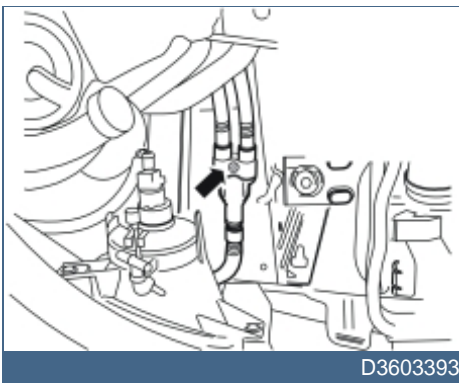

**Point - applies to the S80**

- Remove the screw and the junction connector from underneath the side member.

4

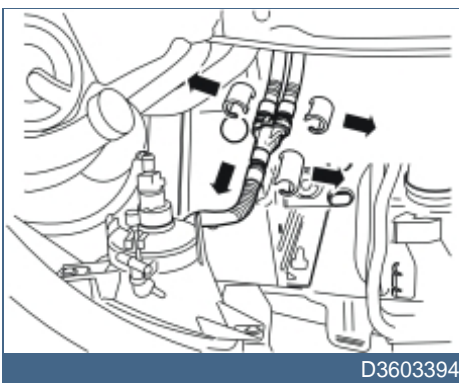

**Point - applies to the S80**

- Remove the locking sleeves over the cable splices on the junction connector. Pull off the connectors from the junction connector
- Place the junction connector to one side. It will not be reused.



5

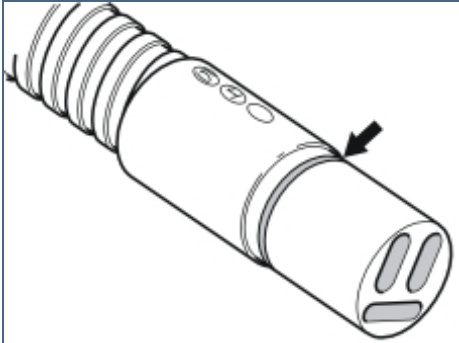

D3601932

## Point - applies to the S80

- Lubricate the O-rings on the connectors for the relay and front engine block heater socket. Use low temperature grease, (P/N 1161417-9).

### Note!

Do not get any grease on the contact surfaces of the connector.

6

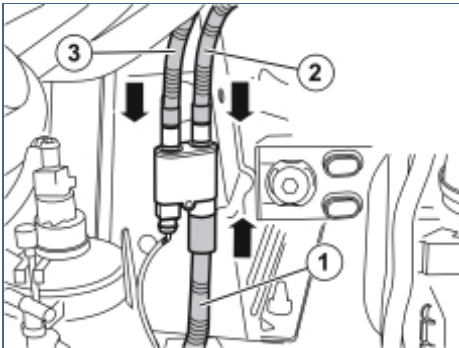

D3603395

## Point - applies to the S80

- Take the relay from the kit. Connect the cable for the front engine block heater socket (1), the cable for the engine block heater (2) and the cable for the passenger compartment connector socket (3). Firmly press the cable splices together.

7



D3603396

## Point - applies to the S80

- Press the locking sleeves from the kit over the joints.

### Note!

The large locking sleeve must be pressed over the connector on the cable from the front engine block heater socket.

8



D3603397

## Point - applies to the S80

- Tighten the relay on the underneath of the side member. Use a screw from the kit in the same hole as the one in which the junction connector is positioned
- Connect the ground lead for the relay to the existing ground terminal at the front end of the side member. Tighten properly
- Secure the ground lead excess by the cable for the front engine block heater socket. Use the tie strap (1) from the kit.



9

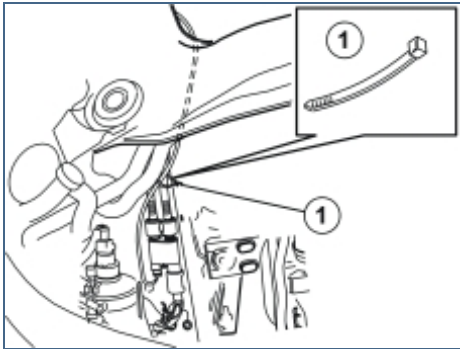

D3603398

## Point - applies to the S80

- Tighten the single cable for the relay on top of the right front corner of the sub-frame. Tighten the cable together with the other wiring for the engine block heater/passenger compartment connector socket
- Secure the single cable for the relay at the existing wiring. Use the tie strap (1) from the kit.

10

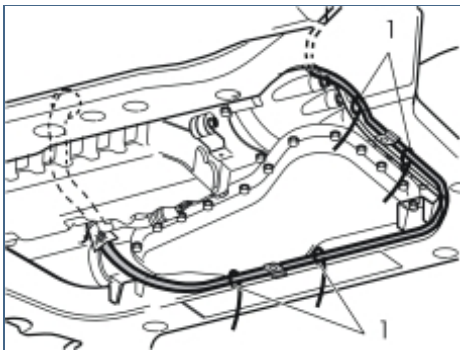

D2900448

## Point - applies to the S80

- Route the single cable along the cable to the passenger compartment connector socket and secure. Use the tie straps (1) from the kit.

11

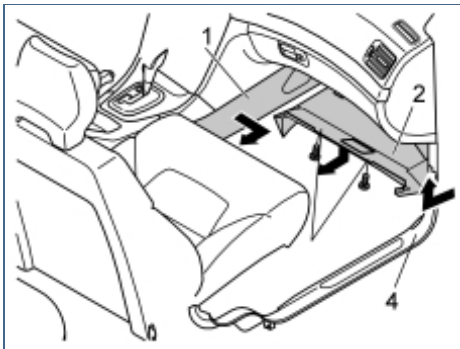

R8504240

## Point - applies to the S80

- Turn the clips at the rear edge of the centre console 45°. Remove the right-hand side panel for the centre console (1). Pull the panel out at the rear edge and then straight back
- Remove the soundproofing panel (2). Remove the three screws (3) first. Then pry the panel from the three clips on the rear side. Pull the panel backwards
- Remove the panel (4) from the right-hand front door sill by pulling the upper front edge backwards. Then pull the panel upwards to release all the clips.

12

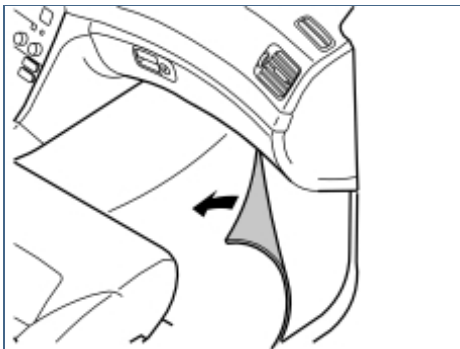

D8703334

## Point - applies to the S80

- Remove the locking sleeve over the joint between the cable and the passenger compartment connector socket. Pull the cable off
- Remove the passenger compartment connector socket
- Push the carpet at the right-hand front seat to one side to access the lead-in to the engine compartment. It is located to the left at the lower edge of the soundproofing panel
- Move the rubber grommet with the cable to the engine compartment.



13

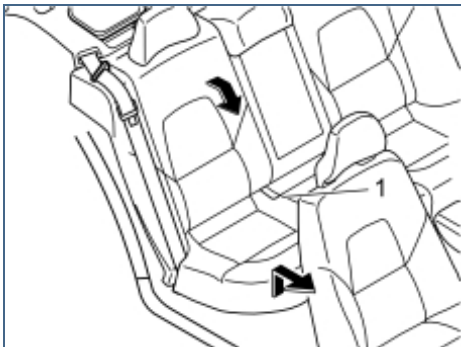

M8503476

**Point - applies to the S80**

- Remove the seat cushion (1). First pull the front edge of the seat cushion up. Pull the cushion forwards. Then lift the seat cushion out
- Fold the right-hand rear backrest forward.

14

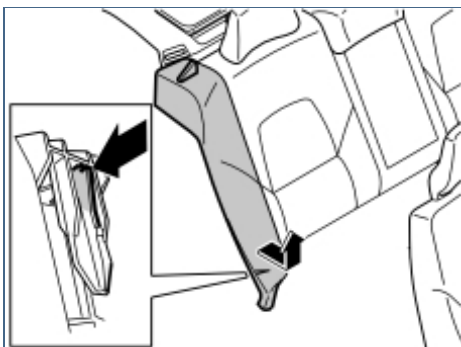

A8504245

**Point - applies to the S80**

- Insert your hand down the side of the lower section of the side cushion. Remove the left-hand side cushion
- Release the catches. At the same time lift the side cushion
- Place the cushion to one side.

15

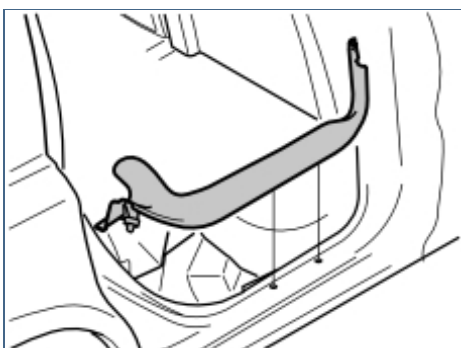

M8503477

**Point - applies to the S80**

- Remove the panel at the right-hand rear door sill. First pull the panel up by the rear edge so the clips release. Then continue pulling forwards so that the remaining two clips release.

16

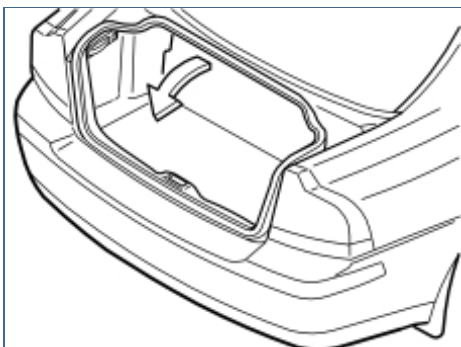

M8503481

**Point - applies to the S80**

- Remove the cargo compartment carpet.





17

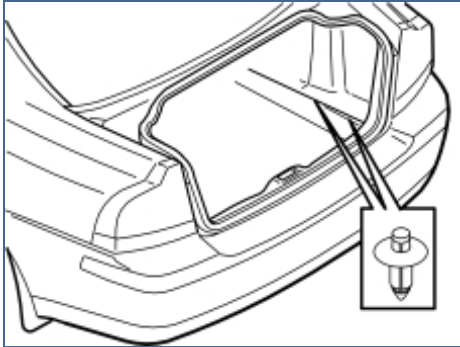

M8503478

## Point - applies to the S80

- Press the centres of the clips at the bottom of the folding side panel on the right-hand side. Press the clips until a click is heard
- Remove the clips.

18

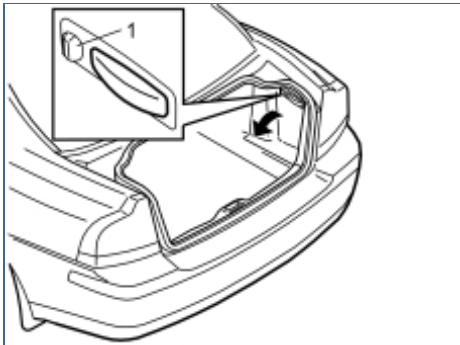

M8503479

## Point - applies to the S80

- Turn the handle (1) on the right-hand side through 90°.
- Fold the side panel inwards. Lift the panel out.

19

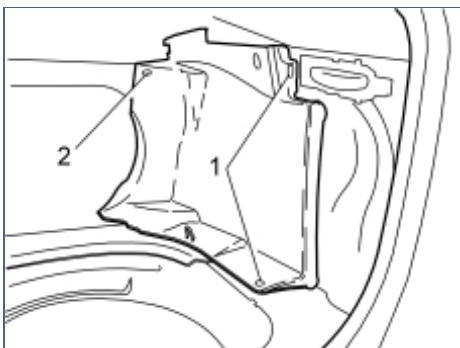

M8503483

## Point - applies to the S80

### Remove:

- the clips (1) in the right front side panel in the cargo compartment
- the clips (2) at the top of the front edge on the side panel for the rear folding backrest
- the panel.



20A

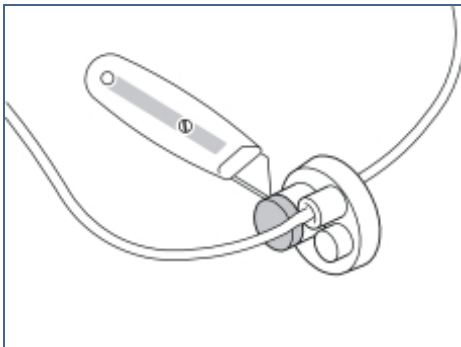

D2900449

## Point - applies to the S80

- Remove the rubber grommet on the cable for the passenger compartment connector socket.
- Cut the top off the large rubber cap on the recently routed rubber grommet for the cable harness
- Apply low temperature grease (P/N 1161417-9) to the rubber grommet to facilitate routing the cable to the passenger compartment connector socket
- Insert the cable for the passenger compartment connector socket. Insert the cable through the rubber grommet.
- Insert the cable for the passenger compartment connector socket and the single cable into the passenger compartment.

20B

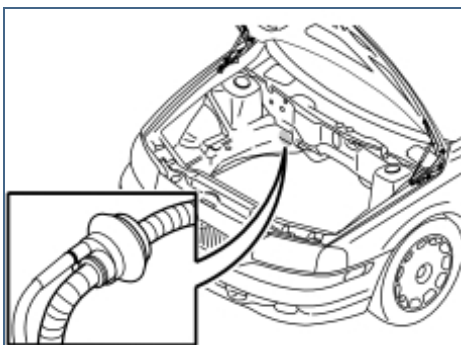

D8200250

21

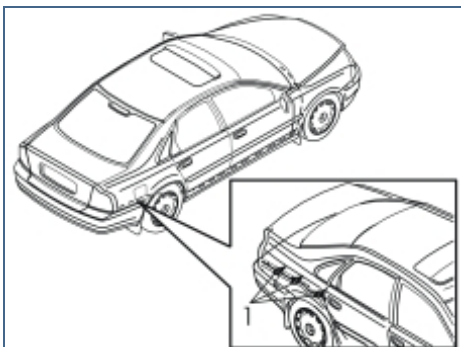

D3703333

## Point - applies to the S80

- Route both cables to the front edge of the sill on the right-hand front door
- Continue to route the single cable along the right-hand side of the car inside the floor carpets and insulation. Route the single cable to the accessory electronic module (AEM) located on the right-hand side in the cargo compartment rear wheel well. Ensure that the single cable is positioned so that there is no risk of it catching or rubbing
- Secure at the cable duct in the cargo compartment. Use the three tie straps (1) from the kit.

22

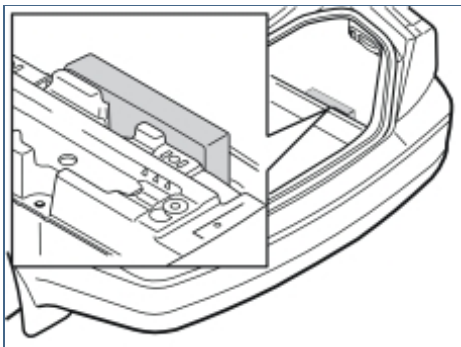

D3703334

## Point - applies to the S80

- Lift the accessory electronic module (AEM) out of the bracket.



23

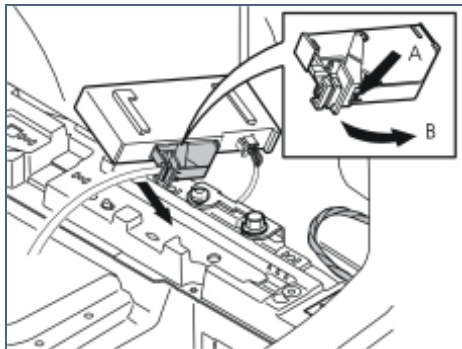

M3702529

### Point - applies to the S80

- Disconnect the large connector from the accessory electronic module (AEM). First press in the catch (A). Pull the locking handle (B) in the direction of the arrow until a click is heard
- Pull the connector out from the control module.

24

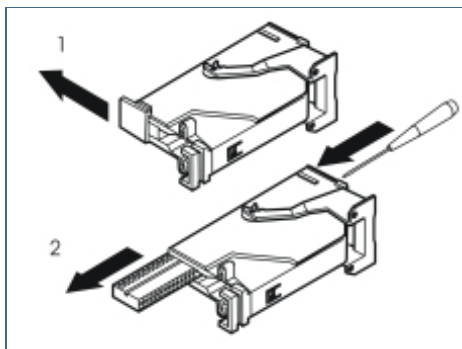

M3702530

### Point - applies to the S80

- Remove the catch holding the switch in place in the connector. Pull the catch in the direction of the arrow
- Remove the switch by inserting a pointed object in the hole on the other end. Press the switch out.

25

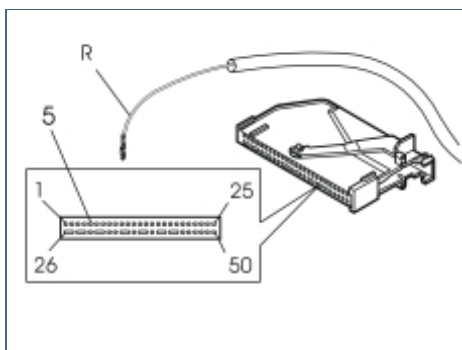

M3702794

### Point - applies to the S80

- Connect the pre routed cable to the accessory electronic module (AEM) connector in terminal 5.

#### Note!

Number markings can be found on the top and bottom of the switch. The markings are very small. Ensure accuracy when installing the cable.

26

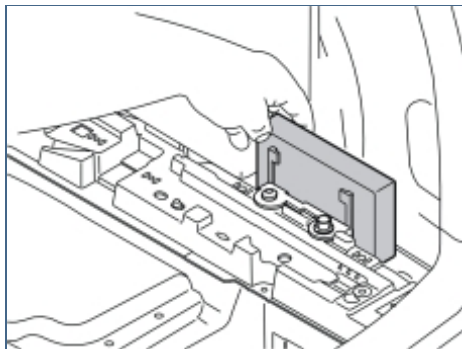

M3702511

### Point - applies to the S80

- Reinstall the switch in the connector. Lock into place using the catch
- Press the connector into the control module and lock using the handle
- Press the control module into the bracket.

27

### Point - applies to the S80

- Reinstall the panels in the cargo compartment



- Reinstall the cargo compartment carpet
- Reinstall the sill trim panel in the rear door
- Reinstall the side cushion
- Reinstall the seat cushion
- Fold the backrest back into place
- Fold the front seat carpet back into place
- Connect the cable for the passenger compartment connector socket. Tighten the cable
- Reinstall the sill trim panel in the front door
- Reinstall the soundproofing panel and side panel for the centre console
- Reinstall the centre air baffle
- Reinstall the engine cover. Tighten the screws. Tighten to **24 Nm (18 lbf.ft)**
- Reinstall the air baffles at the sides (if applicable)
- Program the software according to the service information in VIDA.

28

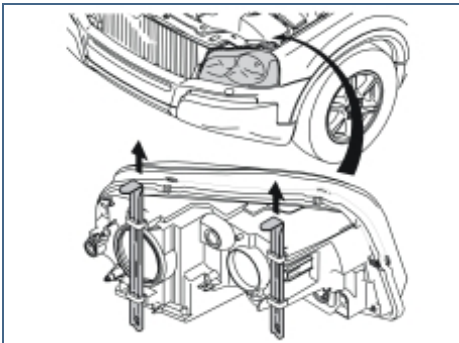

R3501343

#### Point - applies to the XC90

- Detach the left-hand headlamp by pulling up the two cotter pins. Then carefully pull the headlamp forward.

29

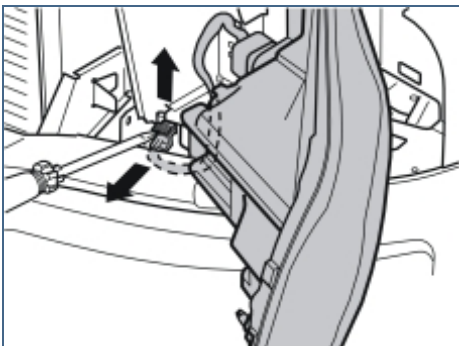

R3501493

#### Point - applies to the XC90

- Carefully pry up the catch on the headlamp connector. Use a screwdriver
- Pull up the catch completely. Disconnect the connector. Place the headlamp to one side.



30

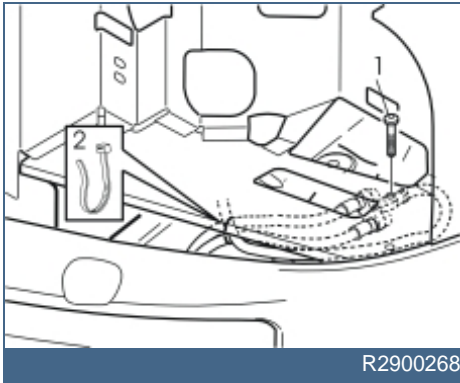

R2900268

## Point - applies to the XC90

- Remove the junction connector together with the wiring from the underside of the plate underneath the headlamp. First remove the screw and the nut (1)
- Cut off the tie strap (2)
- Remove the locking sleeves over the cable splices on the junction connector. Disconnect the wiring
- Place the junction connector to one side. This will not be used again.

31

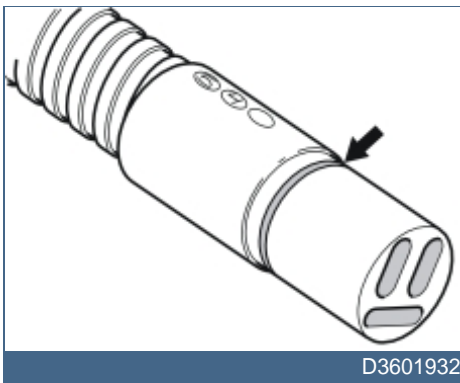

D3601932

## Point - applies to the XC90

- Take the relay and the locking sleeves from the kit
- Lubricate the O-rings on the connectors for the relay and front engine block heater socket. Use low temperature grease, (P/N 1161417-9).

### Note!

Do not get any grease on the contact surfaces of the connector.

32

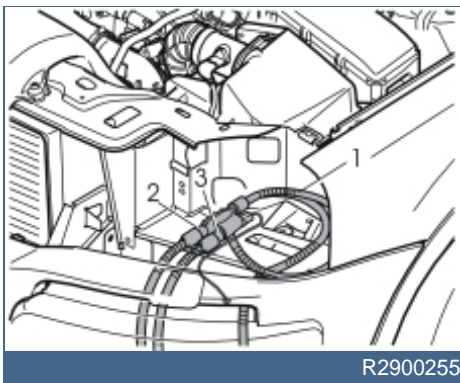

R2900255

## Point - applies to the XC90

- Connect the cable (1) from the front engine block heater socket to the relay
- Connect the wiring for the engine block heater and passenger compartment connector socket to either socket (2) or (3) on the relay.

33

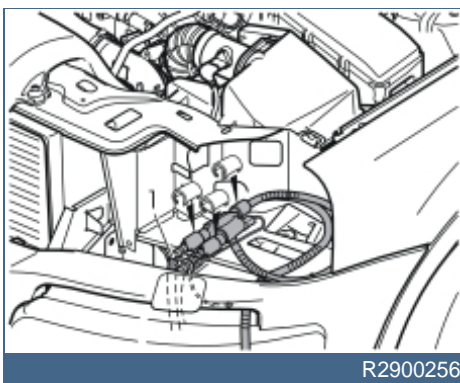

R2900256

## Point - applies to the XC90

- Press the three locking sleeves from the kit over the cable splices.

### Note!

The large locking sleeve must be pressed over the connector on the cable from the front engine block heater socket.

- Secure the power supply cable and the ground lead at one of the cables for the engine block heater/passenger compartment connector socket. Use a tie strap (1) from the kit.



34

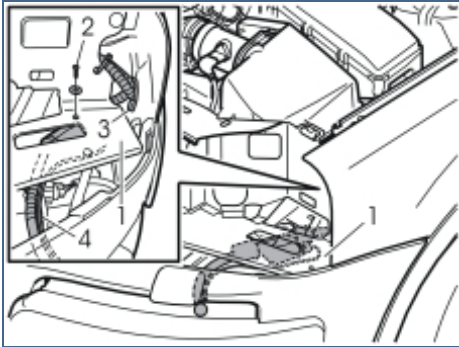

R2900236

## Point - applies to the XC90

- Position the wiring and relay on the under side of the plate (1). Position the relay with the side against the plate to release the switch
- Take a screw, washer and nut (2) from the kit. Tighten the relay to the plate
- Secure the cable for the front engine block heater socket at point (3) in the plastic lug for the bumper cover mounting
- Insert the thin cable together with the ground lead from the relay in the same position as the wiring for the engine block heater /passenger compartment connector socket
- Secure all wiring at point (4). Use a tie strap from the kit.

35

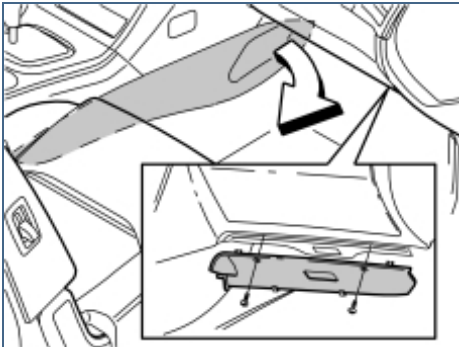

R8504142

## Point - applies to the XC90

- Remove the right-hand side panel from the centre console. Pull off the panel starting at the front edge. Then pull backwards until all the clips release
- Remove the right-hand side soundproofing panel. First remove the two screws. Then pry off the panel at the top edge.

36

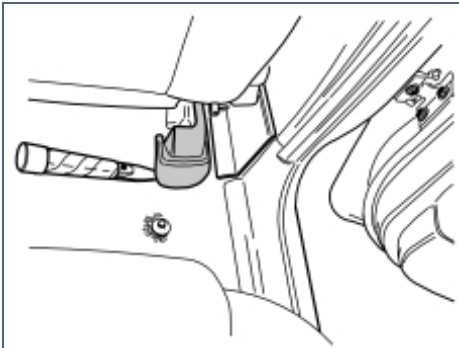

R8504241

## Point - applies to the XC90

- Remove the panel on the right rear mounting on the right-hand front seat. Pry it up slightly at the rear edge and then pull it back / upwards.

37

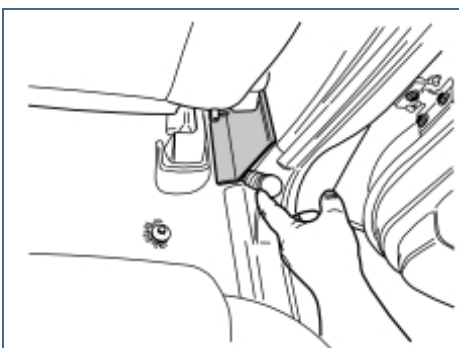

R8504169

## Point - applies to the XC90

- Carefully pry off the panel above the joint between the right-hand door sills, at the lower edge. Use a weatherstrip tool. Remove the panel.



38

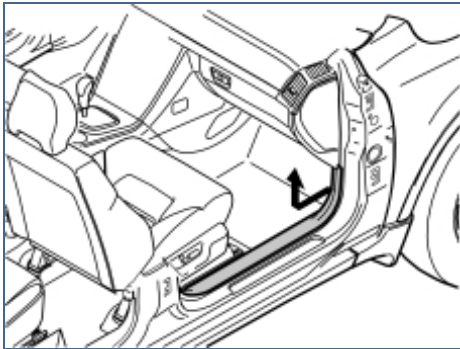

R8504170

## Point - applies to the XC90

- Remove the sill trim panel for the right-hand front door. Pull it off, starting at the front edge, until the clip there has released. Continue backwards until the remaining clips have released
- Unhook the sill trim panel from the B-post panel.

39

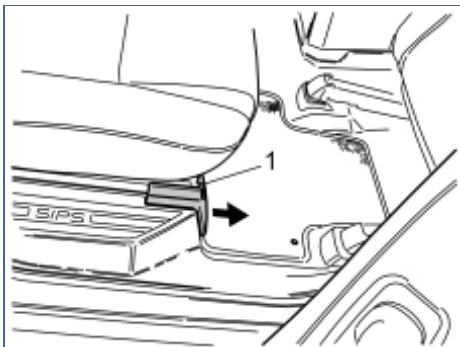

R8504171

## Point - applies to the XC90

- Remove the panel in the right-hand front seat mounting on the right-hand seat in the second row. Push up the catch (1) on the top. Pull the panel forward.

40

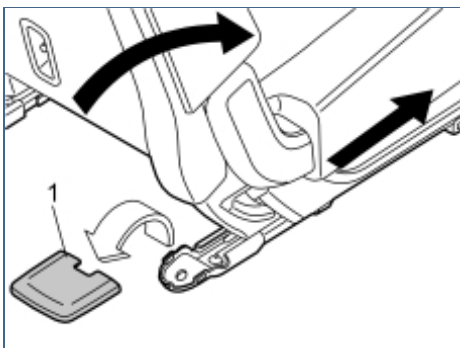

R8504172

## Point - applies to the XC90

- Fold the backrest on the right-hand seat in the second row forward as far as possible. Slide the front seat as far forward as possible. On cars with two rows of seats, the second row is fixed
- Remove the cover (1) for the right rear seat mounting by prying off the rear edge.

41A

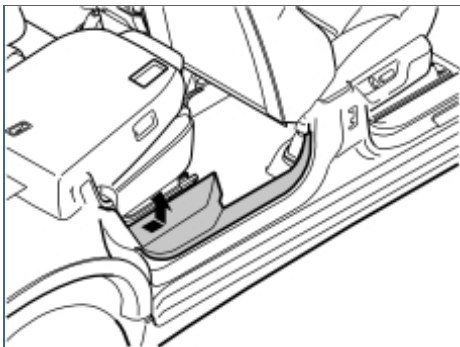

R8504173

## Point - applies to the XC90

### Illustration A

- Remove the sill trim panel for the right-hand rear door. Pull off the rear edge so that the clips release. Continue forwards until the remaining clips have released.

### Applies to cars with two rows of seats

- On cars with two rows of seats the seat cannot be slid forwards. To remove the sill trim panel: First fold the backrest forwards when the rear edge of the sill trim panel is pulled off. Then reposition the backrest to raise the seat cushion and provide more room to remove the sill trim panel. It is securely positioned. Do not damage the panel and surrounding components during removal.



41B

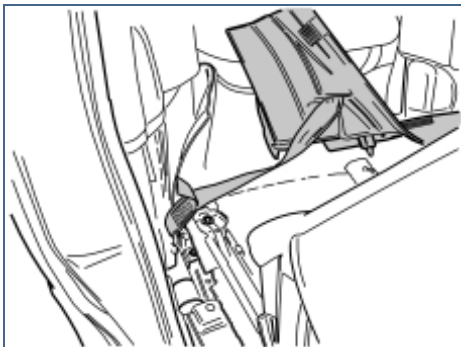

R8504174

## Illustration B

- Unhook the sill trim panel from the B-post panel. Position the panel in the second/third row of seats.

42A

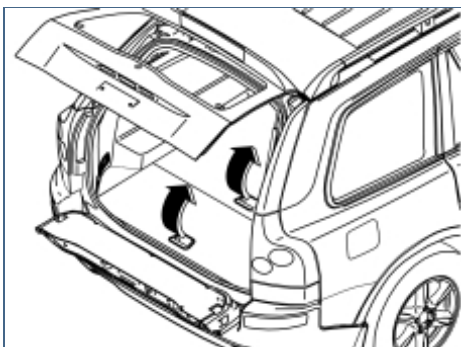

R8902691

## Point - applies to the XC90

### Illustration A

#### Applies to cars with two rows of seats

- Remove the two centre floor hatches. First lift them up slightly and then pull them loose from the mountings at the front edge.

If the rear centre floor hatch is equipped with a carrier bag holder on the lower side, the floor hatch is secured by a strap on each of the shorter sides of the storage box. These must be removed.

- Remove the storage box underneath.

42B

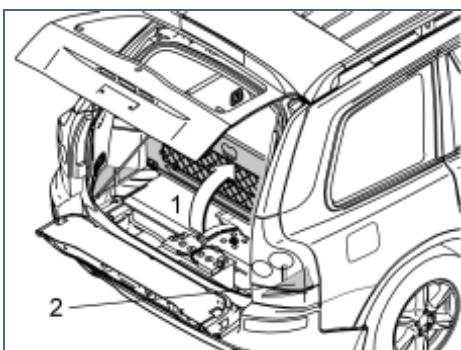

R8902931

### Illustration B

#### Applies to cars with three rows of seats and integrated carrier bag holder on the underside of the centre floor hatch

- Fold up the centre rear floor hatch (1)
- Detach the two straps from the panel underneath. Lift up the rear edge of the panel. Fold the floor hatch back towards the panel and lift out the floor hatch and the panel.

#### Applies to cars with three rows of seats without an integrated carrier bag holder

- Lift up the centre rear floor hatch at the rear edge and lift it out.

#### Applies to all models

- Remove the right-hand side floor hatch (2).





43

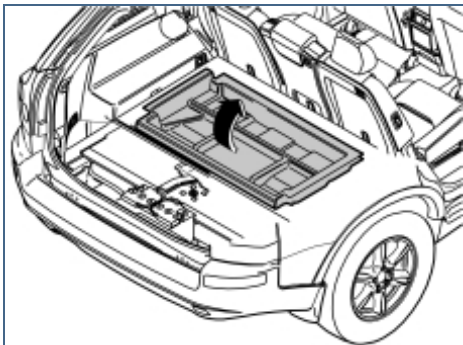

R8504293

## Point - applies to the XC90

### Applies to cars with two rows of seats

- Remove the front storage compartment.

44

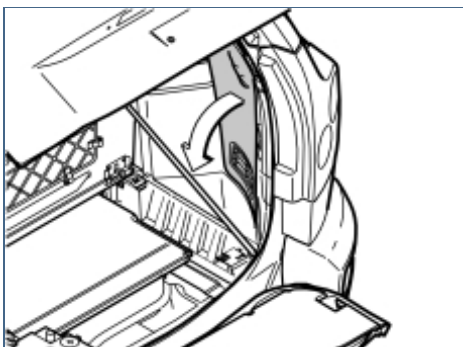

R8504159

## Point - applies to the XC90

- Remove the folding side panel from the right-hand side in the cargo compartment.

45

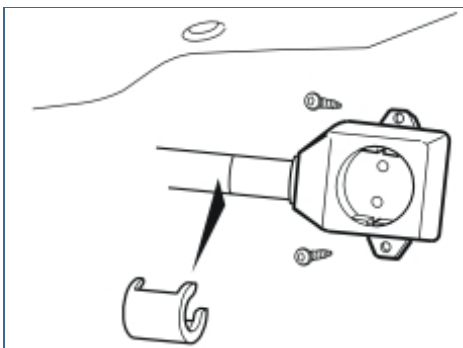

R3602949

## Point - applies to the XC90

- Remove the screws for the passenger compartment connector socket. Remove the passenger compartment connector socket from the bracket inside the carpet
- Remove the locking sleeve. Disconnect the cable from the passenger compartment connector socket.

46

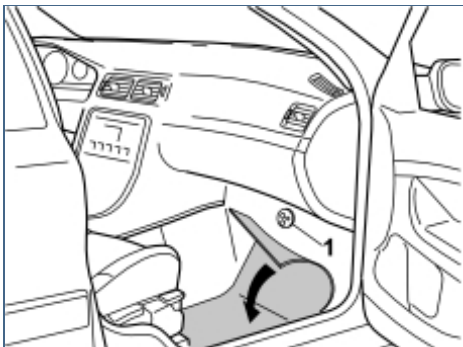

R8504295

## Point - applies to the XC90

- Push the carpet on the front right-hand side to one side
- Press out the rubber grommet in the cowl panel (1).



47

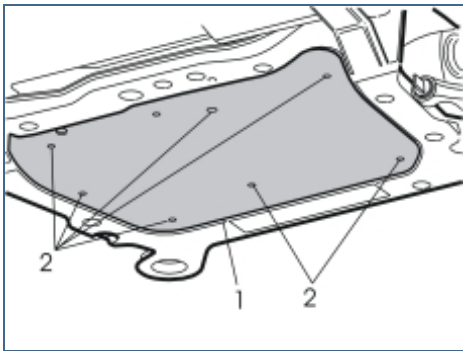

R2000348

### Point - applies to the XC90

- Remove the engine splash guard (1) by first removing the screws (2).

48

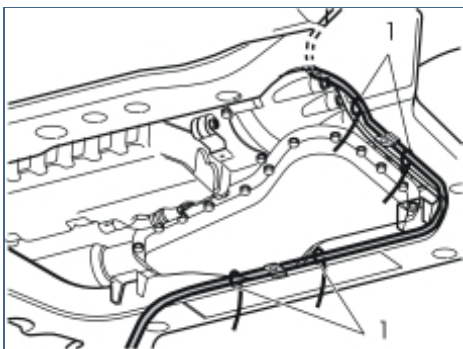

R2900253

### Point - applies to the XC90

- Route the wiring down from the relay.
- Take four tie straps from the kit. Secure the thin power supply cable (not the ground lead) at the cable for the passenger compartment connector socket.

49

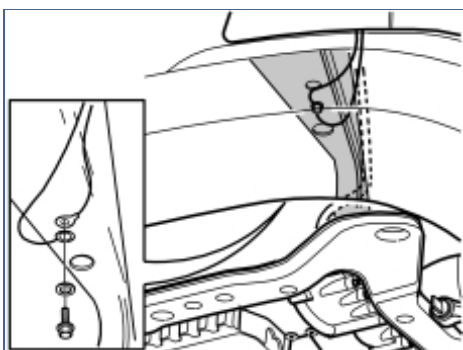

R8600975

### Point - applies to the XC90

- Disconnect the existing ground lead for the front engine block heater socket underneath the left-hand front member
- Route the ground lead to the relay. Connect both ground leads to the existing ground terminal.

50A

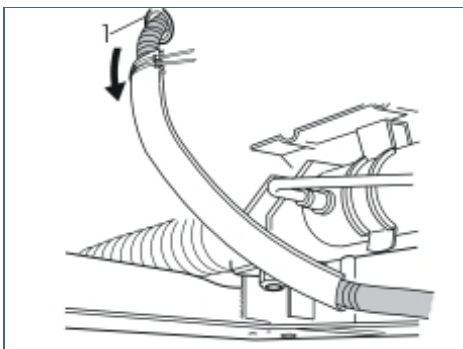

R2900258

### Point - applies to the XC90

#### Illustration A

- Pull off the cable and rubber grommet (1) for the passenger compartment connector socket
- Pull out the entire cable from the hole in the cowl panel. Remove the rubber grommet from the cable. A new rubber grommet is on the routed power supply cable.

#### Illustration B



50B

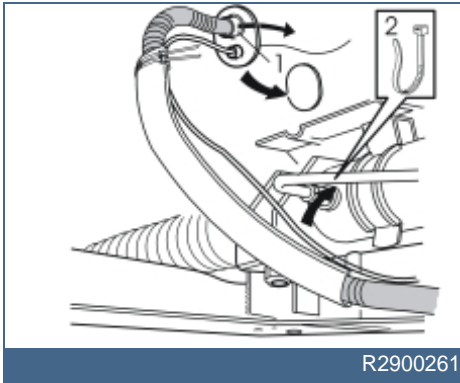

R2900261

- Cut the top off the new rubber grommet (1)
- Insert the cable for the passenger compartment connector socket through the new rubber grommet
- Lubricate the rubber grommet on the side facing inwards in the passenger compartment. Use low temperature grease (P/N 1161417-9)
- Adjust the wiring up to the grommet. Insert the wiring into the hole in the cowl panel
- Carefully route the rubber grommet into position from inside the passenger compartment by pulling the cable for the passenger compartment connector
- Clamp the power supply cable at the power steering pipe. Use a tie strap (2) from the kit.

51

## Point - applies to the XC90

- Reinstall the engine splash guard. Tighten the screws. Tighten to **25 Nm (18 lbf.ft.)**
- Connect the connector to the headlamp. Reinstall the headlamp. Ensure that the headlamp lock pins are correctly positioned: The short innermost and the long wide outside pins.

52

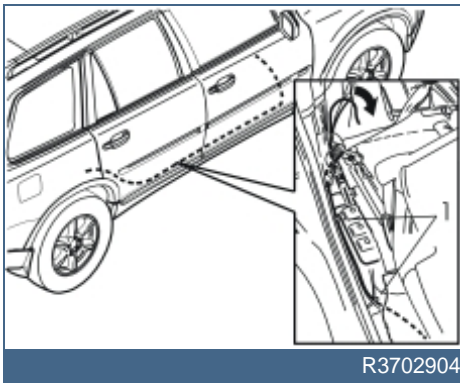

R3702904

## Point - applies to the XC90

- Insert the cable harness between the carpet and the door sill towards the floor as far as it will go. Route it along the right-hand side of the car up to the opening for the right-hand rear door
- Pull the cable up to the right-hand seat mounting on the right-hand seat in the second row of seats
- Pull away the carpet from the front edge of the right-hand side panel in the cargo compartment
- Route the cable to the right-hand side of the air duct towards the front edge of the rear wheel arch. Clamp the cable at the air duct. Use two tie straps (1) from the kit
- Route the cable along the reverse of the air duct and out along the front edge of the wheel arch.



53A

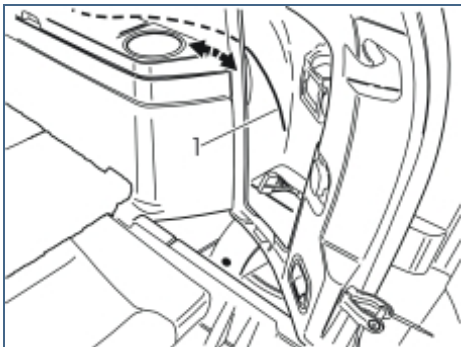

R3702907

**Point - applies to the XC90**

**Applies to cars with three rows of seats** Illustration A

- Insert a cable (1) at the rear edge of the right-hand side panel and along the inside of the panel, above the mountings for the load securing eyelets and to the front edge of the side panel.

**Illustration B**

- Tape the cable harness (2) to the wire and pull it out of the rear edge of the side panel.

53B



R3703023

54

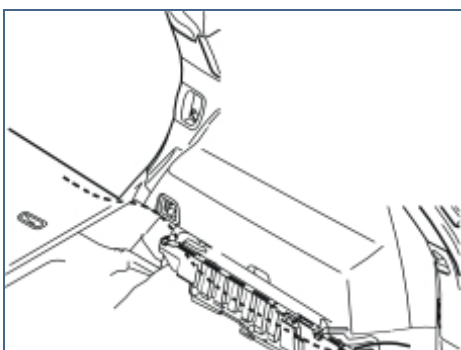

R3702935

**Point - applies to the XC90**

**Applies to cars with two rows of seats**

- Route the cable along the left-hand side of the seat belt mounting at the front edge of the wheel arch. Route the cable inside the carpet at the front edge of the side panel, between the side panel and the cargo floor support, to the accessory electronic module (AEM).

55

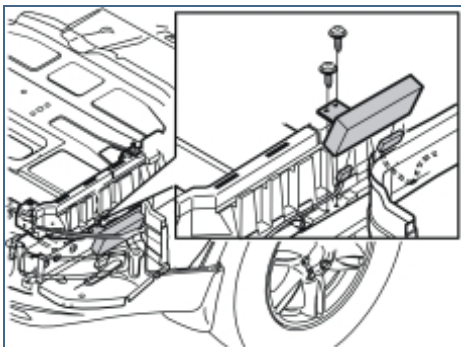

R3702881

**Point - applies to the XC90**

- Remove the two screws from the bracket for the accessory electronic module (AEM) and lift up the entire unit. Cut off the tie straps if necessary.



56

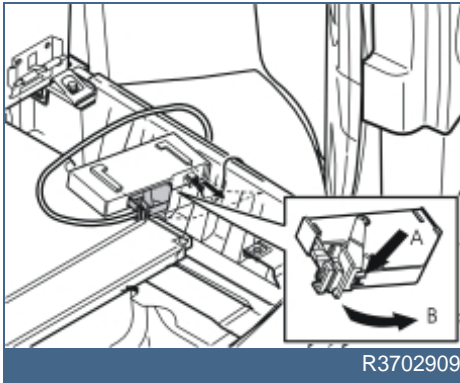

## Point - applies to the XC90

- Disconnect the large connector from the accessory electronic module (AEM). First press in the catch (A). Pull the black locking handle (B) in the direction of the arrow until a click is heard. Disconnect the connector
- Disconnect the connector from the accessory electronic module.

57

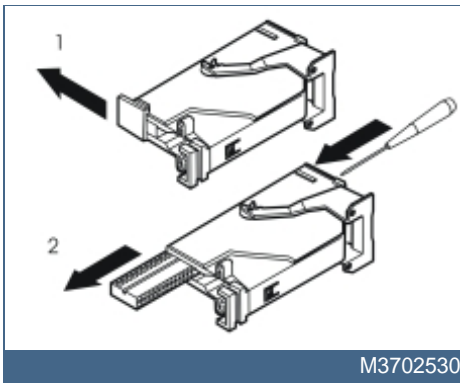

## Point - applies to the XC90

- Remove the black catch holding the black switch in place in the connector. Pull the catch in the direction of the arrow
- Remove the black switch. Insert a pointed object in the hole on the other end of the connector. Press the switch out.

58

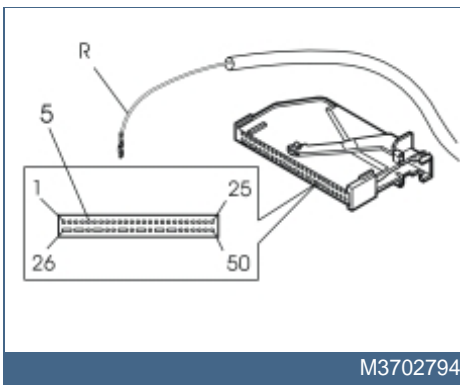

## Point - applies to the XC90

- Connect the pre-routed cable to terminal 5 in the accessory electronic module (AEM) connector.

### Note!

The numerical markings can be found on the top and bottom of the connector. However, the markings are extremely small so take care when installing the cable.

59

## Point - applies to the XC90

- Reinstall the black switch in the connector. Lock into place using the catch
- Press the connector into the accessory electronic module (AEM). Secure using the black locking handle
- Reinstall the accessory electronic module (AEM) and the bracket. Clamp the wiring. Use the tie strap from the kit
- Reinstall the folding panel on the right-hand side in the cargo compartment
- Reinstall the right-hand side floor hatch
- Reinstall the storage boxes



- Reinstall the rear floor hatch(es)
  - Reinstall the carpet at the front edge of the right-hand side panel
  - Reinstall the sill trim panels in the doors on the right-hand side. Reinstall the panel over the cable splice between them
  - Reinstall the panel and cover on the right-hand mountings on the right-hand seat on the second row of seats
  - Reinstall the panel on the right rear mounting of the right-hand front seat
  - Fold the carpet back on the right front side
  - Reinstall the passenger compartment connector socket
  - Reinstall the soundproofing panel. Reinstall the right-hand side panel on the centre console
  - Program the software according to the service information in VIDA.
-