



## XC90

Section	Group	Weight(Kg/Pounds)	Year	Month
8	89		2004	10

XC90 2003, XC90 2003, XC90 2004, XC90 2004, XC90 2005, XC90 2005

Replaces issue: 2004 04

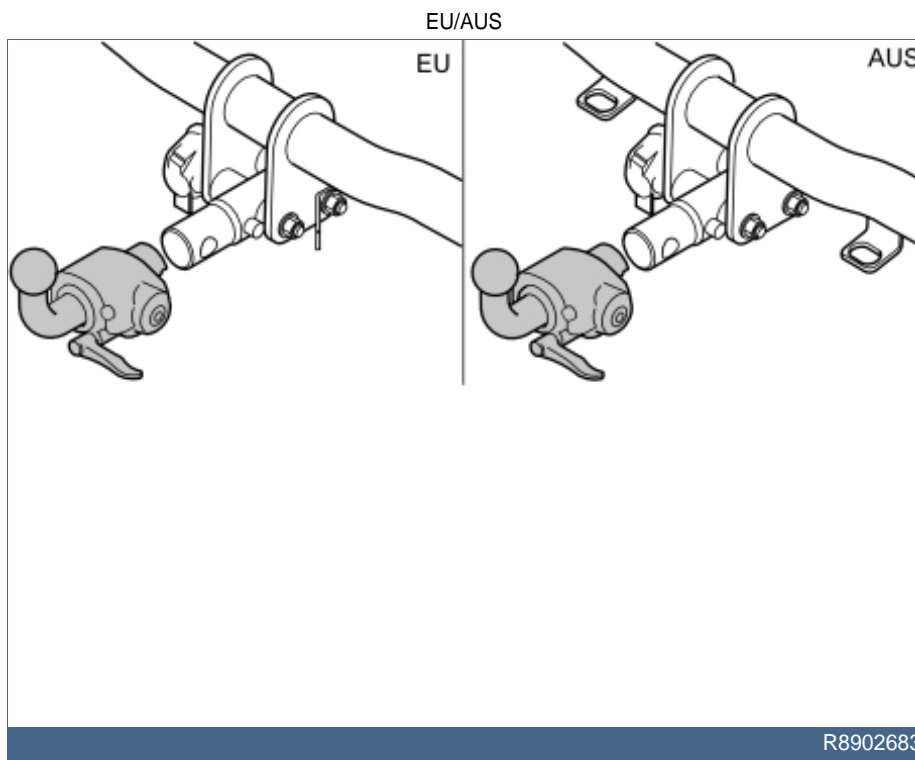

# Installation instructions, accessories - Tow hitch, detachable

Volvo Car Corporation Göteborg, Sweden



## Required tools



A0000162



Nm  
lbf.ft

A0000161

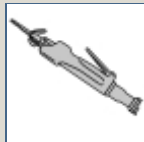

A0000165



A0000235

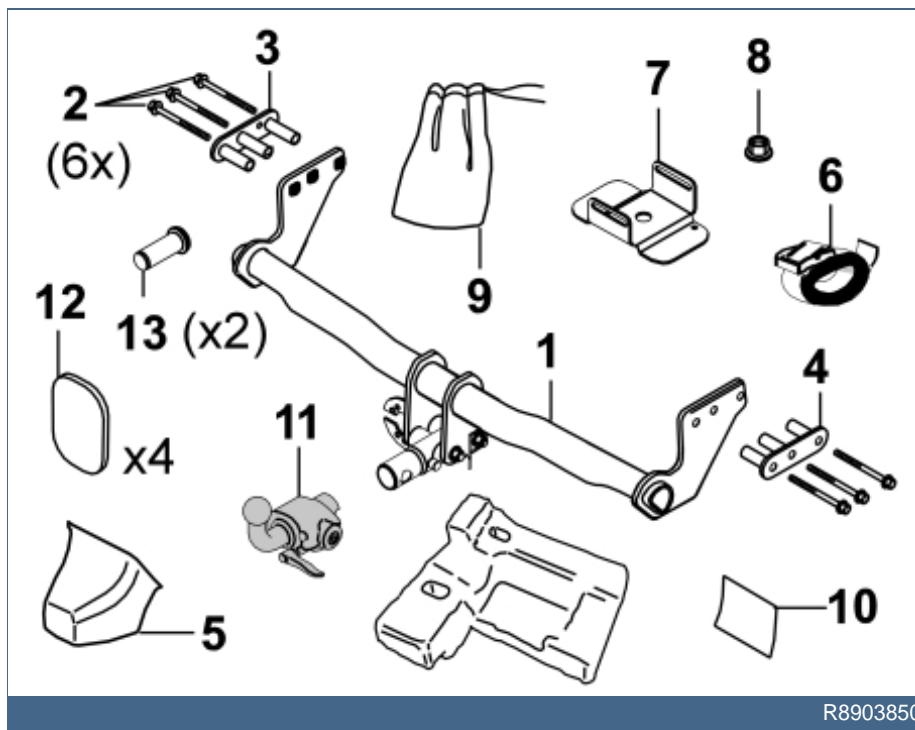
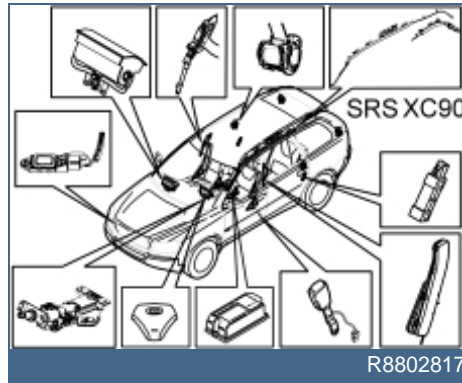

# Installation instructions, accessories - Tow hitch, detachable

Volvo Car Corporation Göteborg, Sweden



Part no:	Kit no:	Supplier no:	Model	EU approval no:	D-value	Vert. load Kg (lbs)
8698922	8698921	60-140600	C	E11*94/20*3605*0	12.2 kN	90 kg

Part no:	Kit no:	Supplier no:	Model	Checked in_ accordance with	D-value	Vert. load Kg (lbs)
8698925	8698924	60-144100	C	ADR 62/01	12.2 kN	90 kg

IMG-223840

Any comments on this publication? Please contact your nearest retailer. Thank You!

Publ.no:	Issue:	Kit no:
Comments:.....		
.....		
.....		
.....		

From:	
Address:	
Telephone:	
Telefax:	

IMG-213320



## INTRODUCTION

- **NOTE! Read through the entire text before carrying out any work.**
- The front page gives the date of this edition and the edition it replaces
- The second page shows the tools needed for the installation and the contents of the installation kit
- The illustrations display the procedure in order of operation. The order of operation is repeated in the text section
- Cut out the text page in order to follow the illustrations and text at the same time.

## Cars equipped with SRS/SIPS (Airbag)

### Warning!

Extra care must be taken when working on cars equipped with SRS/SIPS air bags. This is important to prevent:

1. Personal injury
2. Damage to or malfunction of the SRS/SIPS system.

Work on the SRS/SIPS systems or related components must always be carried out by an authorised Volvo workshop.

## Is the car equipped with SRS (supplemental restraint system)?

Cars equipped with a driver's airbag have the letters "SRS" imprinted on the centre panel of the steering wheel. Cars equipped with driver's and passenger airbags are marked with "SRS" on both the steering wheel centre panel and also on the dashboard close to the airbag.

If the car is equipped with SIPS (side impact protection system ) a "SIPS" decal is marked on both the front seats.

Cars equipped with inflatable curtains have the marking "SRS" on one of the panels along the posts on the inside of the car.

Cars equipped with SRS (supplemental restraint system) also have a "SRS" decal on the front windscreen.

### Do not damage the SRS wiring!

Do not trap, fray, pierce or damage the SRS wiring. SRS wiring has orange casing and/or is plaited.

### Steering and front suspension

The contact reel in the SRS system can easily be damaged when working on the steering wheel, steering shaft or steering gear. Refer to the SRS (supplemental restraint system) Service Manual or service instructions in VIDA for information on carrying out such work. This is to prevent damage.

### SRS warning lamp

If the SRS warning lamp lights after repairs have been carried out, take the car to an authorised Volvo workshop.

### SRS collision sensor control module

#### S60 / V70 (00-) / S80 / XC90

The collision sensor control module is located on the transmission tunnel



in the centre console, in front of the parking brake.

**WARNING!**

**The air bag inflation areas must not be obstructed. Never place any objects, such as upholstery or accessories, within these areas. The panels must be able to deploy in the correct manner at the right time otherwise there is a risk of personal injury in the event of a collision.**

**WARNING!**

**The ignition must be in position "0" and the key removed from the ignition if any connector in the SRS system is to be disassembled. Then wait at least one minute. Then disconnect the battery negative lead before disassembling any of the connectors. When work is completed the ignition key must be turned to position "II" before reconnecting the battery negative lead.**

**Tow hitch, detachable**

<p><b>Note!</b></p> <p>Kit contents:</p> <p>Cross member</p> <p>Screw M12x110 (x6)</p> <p>Spacer washer, left-hand</p> <p>Spacer washer, right-hand</p> <p>Protective cover, assembly</p> <p>Strap</p> <p>Bracket</p> <p>Nut M6</p> <p>Protective bag</p> <p>Decal</p> <p>Detachables tow hitch</p> <p>Cover plate (x4)</p> <p>Mounting pin (x2).</p> <p>Type approval of the tow hitch is in the table on page 2.</p>
--



1A

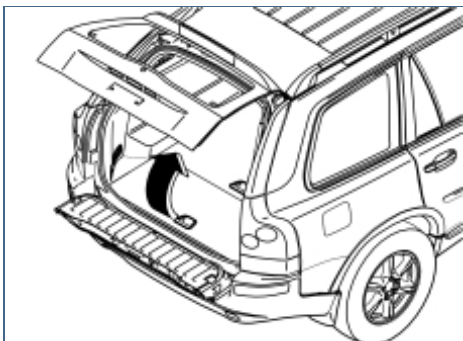

R8902557

## Illustration A

### Applies to cars with two rows of seats

- Fold up the centre rear floor hatch (1) slightly
- Remove the hatch by pulling it off the mountings at the front edge
- Remove the storage box underneath and lift it out. If the floor hatch has a carrier bag holder on the underneath, it is secured by a strap on each of the shorter sides of the storage box. These straps must be undone.

1B

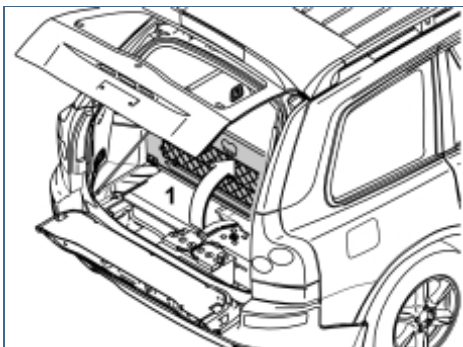

R8903031

## Illustration B

### Applies to cars with three rows of seats and the integrated carrier bag holder on the underside of the centre floor hatch

- Fold up the centre rear floor hatch (1)
- Release the two straps on the panel underneath. Lift up the panel at the rear edge. Fold back the floor hatch towards the panel. Lift out the floor hatch and panel.

### Applies to cars with three rows of seats without an integrated carrier bag holder

- Fold up the centre rear floor hatch (1) at the rear edge and lift it out.

1C

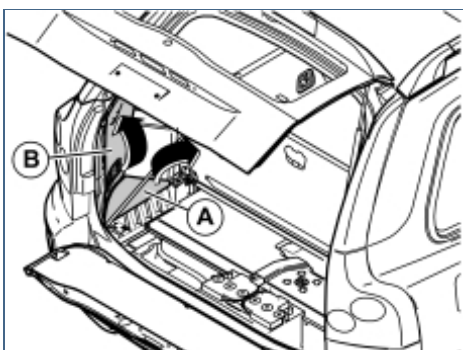

R8903030

## Illustration C

### Applies to all models

- Remove the side floor hatches (A) and the folding side panels (B) on the right and left-hand sides in the cargo compartment.

2

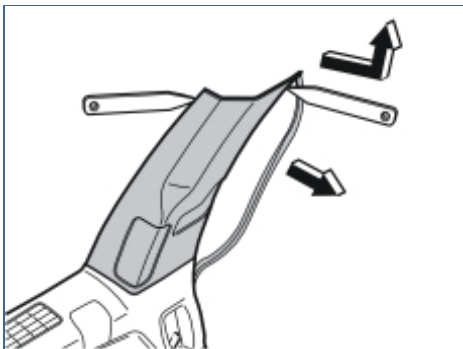

R3903738

- Pull off the rubber strip at the rear edge of the door opening for the left-hand rear door opposite the left C-post panel
- Carefully pry off the left-hand C-post panel at the sides at the top edge. Use a plastic weatherstrip tool. Pull off until the three clips on the inside release. Do not damage the headlining or the panel
- Remove the panel by pulling upwards slightly and unhooking it from the side panel
- Repeat the operation on the right-hand side.



3

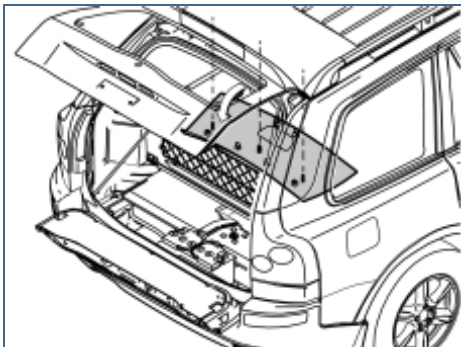

R8504084

- Remove the covers and the screws underneath for the rear headlining
- Carefully pry off the panel at the rear edge. Use a plastic weatherstrip tool
- Pull the rear edge of the panel downwards until all clips on the inside have released
- If the car has lighting in the panel, disconnect the connector
- Pull the panel backwards to release it.

4

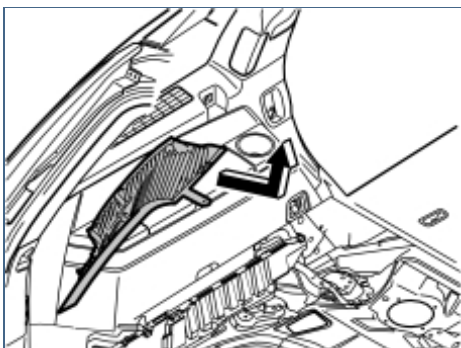

R8504123

- Carefully pull off the left-hand D-post panel starting at the top edge. Then pull downwards until the three clips on the inside have released. Do not damage the panel
- Remove the panel by pulling upwards slightly and unhooking it from the side panel
- Disconnect the connector if the car has a loudspeaker in the D-post
- Repeat the operation on the right-hand side.

5A

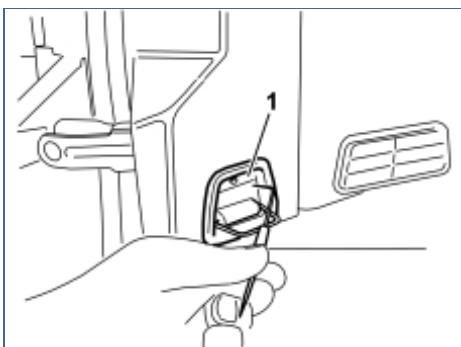

R8504313

**Illustration A shows the removal of the cover for the load securing eyelets**

**Applies to all models**

- Fold out the load securing eyelet
- Insert a scribe with an angled tip into the hole in the top of the cover
- Turn the scribe so that the angled tip engages in the reverse of the cover (1). Pull the cover off
- Repeat the operation on the right-hand side.

5B

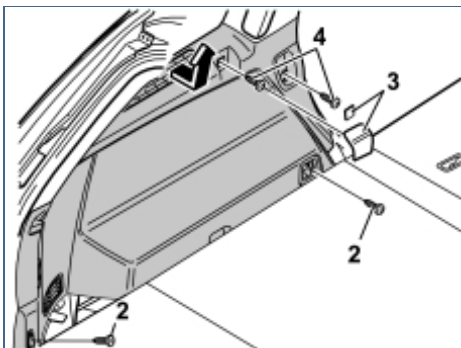

R8504315

**Illustration B applies to cars with two rows of seats**  
**Illustration C applies to cars with three rows of seats**

- Fold up the seats in the third row (applies to cars with three rows of seats)
- Remove the screws (2) for the load securing eyelets in the left-hand side panel
- Remove the covers (3) over the front mountings for the left-hand side panel. Pry the covers off. Use a plastic weatherstrip tool or a small screwdriver
- Remove the screws (4)



5C

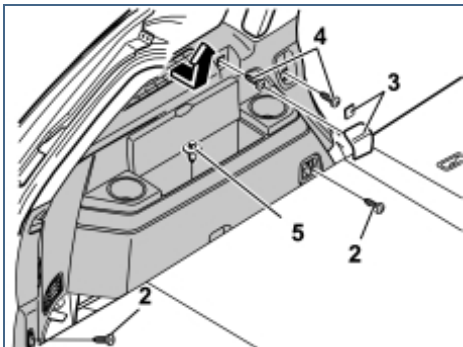

R8504316

- Remove the clip (5) at the bottom of the storage compartment in the panel (Applies to cars with three rows of seats)
- Pull up the panel slightly at the top edge so that the clips on the inside release. Remove the panel by pulling it straight upwards.

6

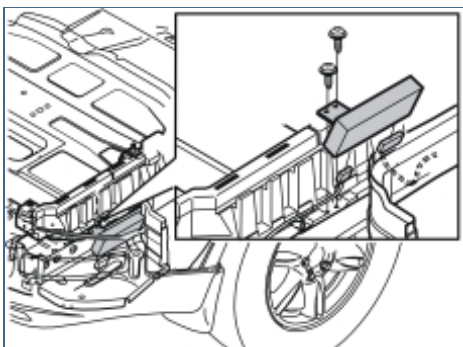

R3702881

- Applies to cars with accessory electronic modules (AEM)**
- Remove the bracket and the accessory electronic module (AEM). If necessary disconnect the connectors.

7

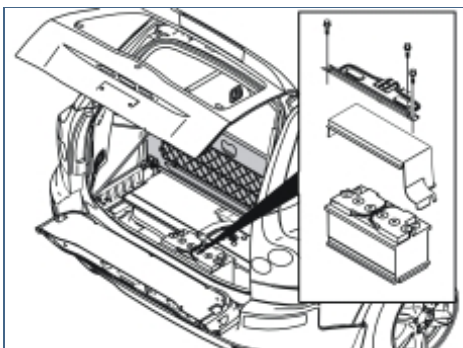

R3100130

- Remove the three screws in the battery holder. Lift the battery holder out
- Remove the battery cover
- Lower and remove the spare wheel.

8A

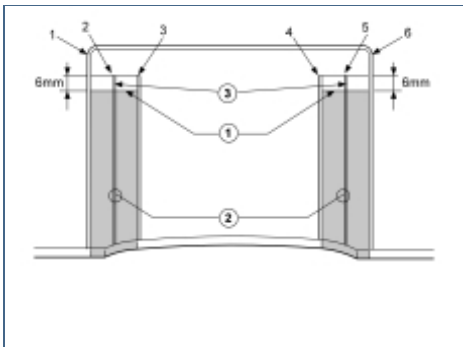

R8601012

## Illustration A

### From underneath the car

1. Measure and draw a horizontal line 6 mm below the top of the ribs as illustrated
2. Cut along the inside of ribs 1 and 3 (the sides which face rib 2) up to the line drawn 6 mm below the top edge of the ribs. Do the same between ribs 6 and 4. Remove the shaded areas by cutting/sawing between the cuts along the horizontal line so that two parallel slits are made in the bumper cover
3. Cut away the remaining pieces of ribs 2 and 5 parallel to the bumper cover.





8B

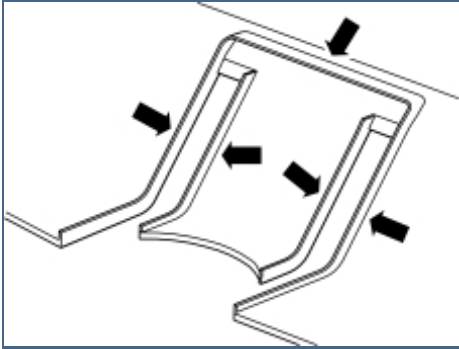

- Use a file to smooth off the edges of the cut outs.

#### Illustration B

- Cut away all the upright ribs.

#### Illustration C

- The end result must be as illustrated.

8C

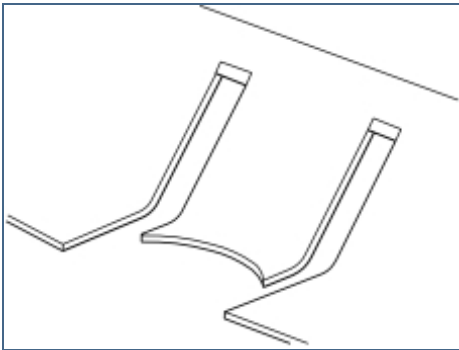

9

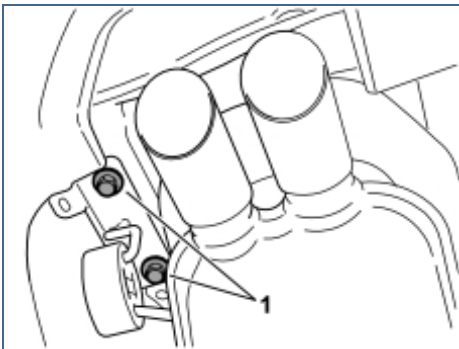

- Remove the rear mounting for the silencer and the bracket from the underneath of the left-hand rear side member by removing the screws (1). Remove the silencer to gain access when installing the tow hitch.

10

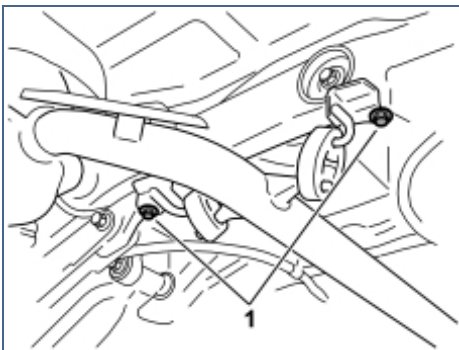

- Remove the front mounting for the rear silencer at the rear sub-frame by removing the screws (1)
- Carefully bend the heat deflector plate at the side member to one side, to gain more work space
- Remove the protective flaps covering the mounting holes on the inside of the side members (one on each side)
- Remove any sealant from the surface where the tow hitch member will be mounted.



11A

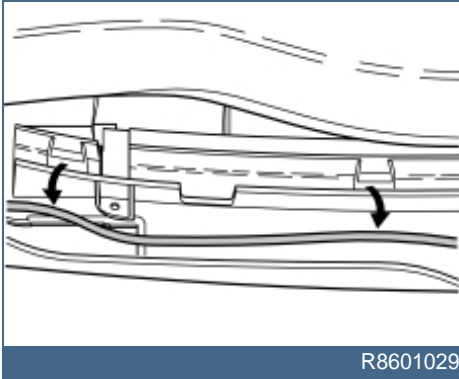

**Applies to cars equipped with a reversing warning system**  
**Illustration A shows the right-hand side of the bumper**  
**Illustration B shows the left-hand side of the bumper**

- Disconnect the cable for the reverse warning sensor from its clips in the rear section of the bumper.

11B

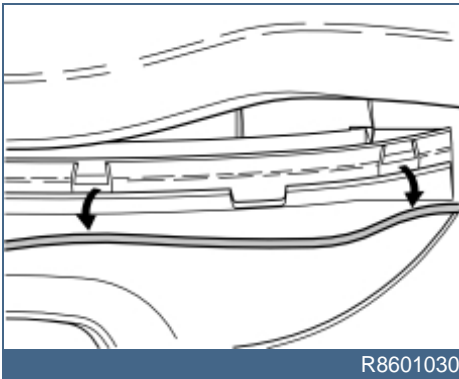

12

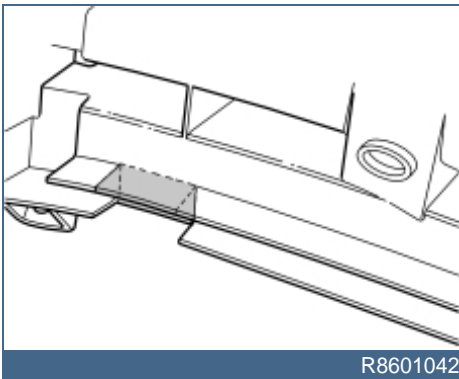

**Applies to all models**

- Right-hand side:**
- Cut out the rear section at the existing cut out as marked in the illustration.

13

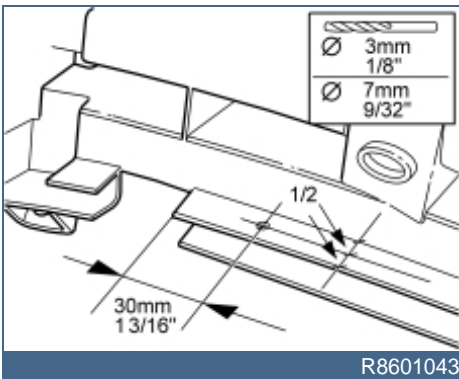

**Applies to cars with reversing warning systems**

- Right-hand side:**
- Measure up to drill the cable lead-in in the upper of the rear section plates as illustrated
  - Pre-drill using a **3 mm (1/8")** diameter drill bit. Then drill out the hole to a diameter of **8 mm (5/16")**. Use an angle drill and short drill bits.



14

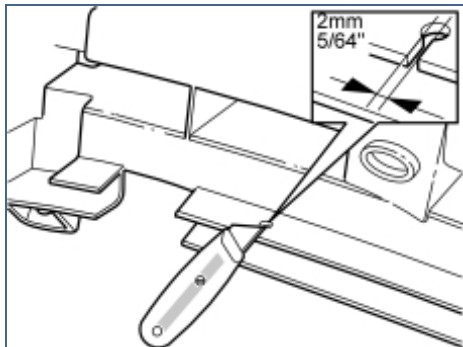

R8601044

- Cut a 2 mm (5/64") wide groove through the plate leading in to the hole.

15

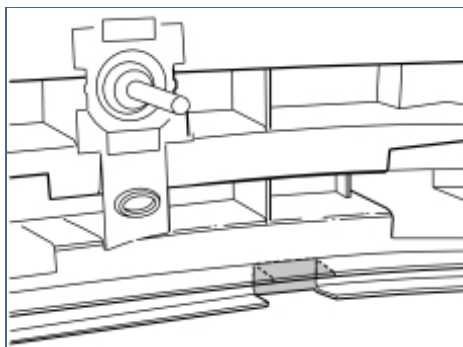

R8601045

### Applies to all models

#### Left-hand side:

- Cut out the rear section at the existing cut out as marked in the illustration.

16

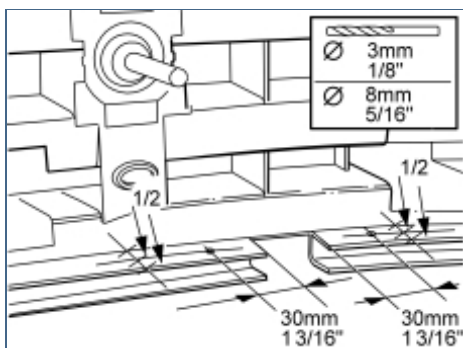

R8601046

### Applies to cars with reversing warning systems

#### Left-hand side:

- Measure up to drill the cable lead-in on the left and right-hand sides of the cut-out in the upper of the rear section plates as illustrated
- Pre-drill using a 3 mm (1/8") diameter drill bit. Then drill out the holes to a diameter of 8 mm (5/16"). Use an angle drill and short drill bits.

17

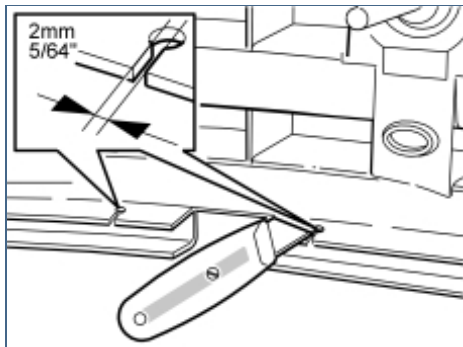

R8601047

- Cut a 2 mm (5/64") wide groove through the plate leading in to the holes on both sides of the cut-out.



18

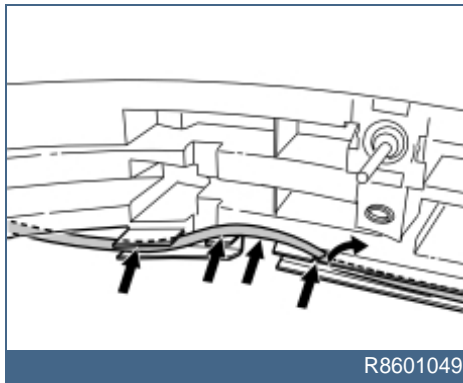

R8601049

**Right-hand side:**

- Press up the tab on the plate. Insert the cable in the previously drilled hole. The cable must be positioned as illustrated.

19

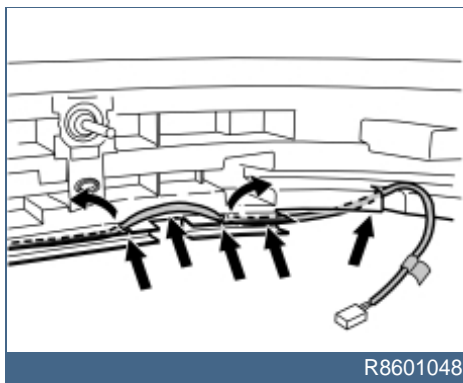

R8601048

**Left-hand side:**

- Press up the tabs on the plates and insert the cable in the holes drilled earlier. The cable must be positioned as illustrated.

20

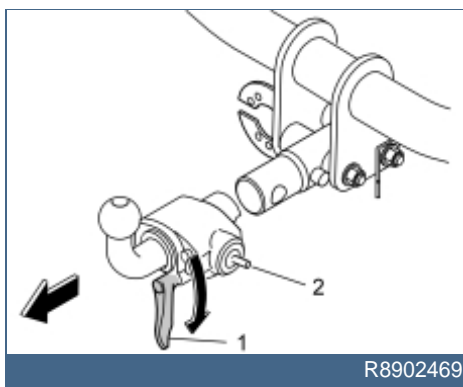

R8902469

- Remove the tow hitch by turning the handle (1) to the right until a click is heard and the pin (2) is in the outer position. Pull out the hitch.

**Note!**

The shaft is greased.

21A

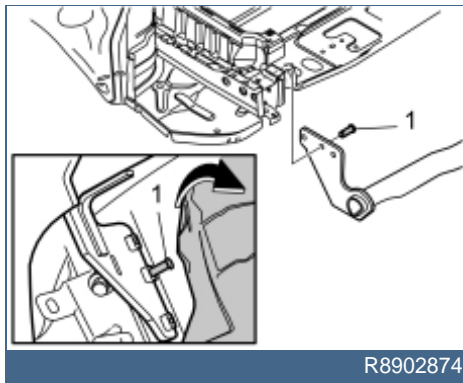

R8902874

It is recommended that two people carry out this procedure.

**Illustration A**

- Take the two mounting pins (1) from the kit
- With one person at each end, lift and position the tow hitch on the inside between the two side members, in between the holes. Start by angling up the face of the left-hand side above the tail pipe on the silencer and up between the heat deflector plate and the side member. Then angle the right-hand side face up to the side member



21B

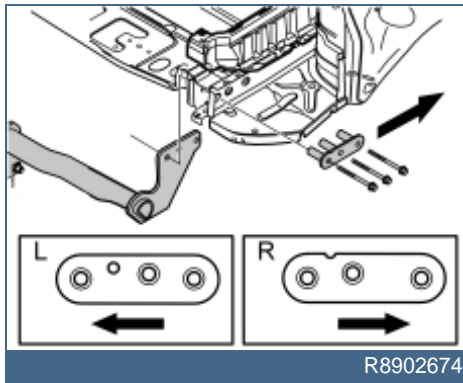

- Press the mounting pins into the centre hole in the side members while holding the tow bar member in position so that the bar can hang freely without falling off
- Carefully lower the car.

## Illustration B

- Fold down the lower tailgate.

### From the inside of the cargo compartment:

- Remove the protective flaps covering the mounting holes on the outside of the side members (one on each side)
- Remove any sealant from the surfaces where the spacer washers will be positioned
- Insert the spacer sleeves using only the front and rear screws on the outside of the two side members.

#### Note!

Be careful when installing the spacer sleeves and screws so that they do not press out the mounting pins, causing the tow bar to detach.

- Screw the front and rear screws in fully but do not tighten them
- Insert the centre screws so that the mounting pins are pressed out. Screw the screws in fully but do not tighten them
- Hold the bar in the horizontal position. Tighten the screws.

#### Note!

Rustproofing agent must be applied under the car before the screws are tightened. Apply the rustproofing agent to the side members all around the ends where any sealant was scraped off.

- Tighten all screws from inside the car. Tighten to **120 Nm (86 lbf.ft.)** in the following order:
  1. The rear screws
  2. The front screws
  3. The centre screws

#### Note!

Wait five minutes so that the joint settles. Then re-check the torque.

- Raise the car again.



22

#### From underneath the car

- Carefully bend the heat deflector plate back into position so that it is not against the silencer
- Reinstall the front mounting for the rear silencer. Tighten the screws. Tighten to **24 Nm (18 lbf.ft.)**
- Reinstall the rear mounting for the rear silencer. Tighten the screws. Tighten to **48 Nm (35 lbf.ft.)**.

23

- Install the cable harness connector for the tow hitch according to point 1D in the installation instructions for the appropriate cable harness.

24

- Install the cable harness according to point 3 onwards in the installation instructions for the appropriate cable harness.

#### Note!

Ensure that the cable harness does not rub against the lower edge of the bumper and is not pressed back.

25A

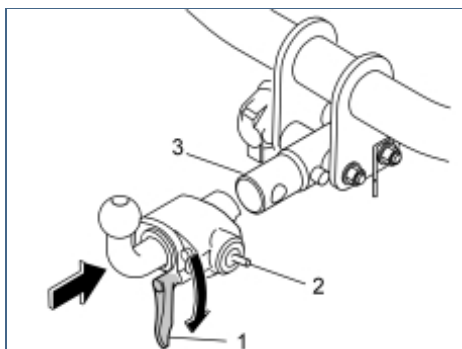

R8902475

- Check the function of the detachable tow hitch.

#### Illustration A displays installation of the tow hitch

- Turn the handle (1) clockwise until a click is heard and the indicator pin (2) is in the outer position
- Install the tow hitch by pressing the tow hitch onto the connection stud (3).

#### Illustration B displays how to lock the tow hitch

- Check that the indicator pin (2) is in the inner position and that the handle (1) is horizontal
- Turn the lock cylinder (3) to the position illustrated.

25B

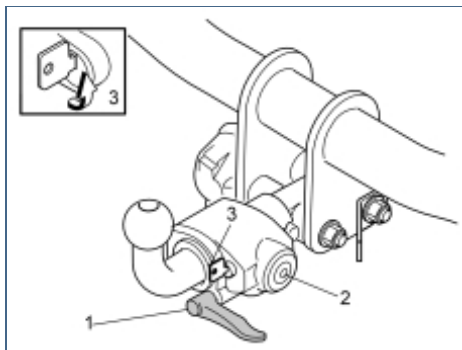

R8902387



26A

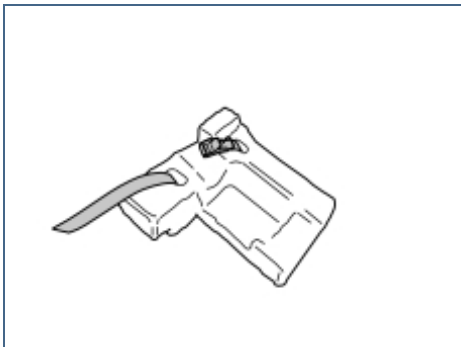

R8903851

## Storing the tow hitch

Applies to cars with three rows of seats

### Illustration A

- Remove the storage box and the strap from the kit. Thread the strap through the holes in the storage box. See the illustration.

### Illustration B

- Insert the storage box in the space to the right of the battery. Press the box into place against the floor. Be careful with the storage box. It is made of Frigolite which is brittle.

### Illustration C

- Thread the supplied protective bag over the towing ball before removing the tow hitch
- Remove the tow hitch. Pull the string tight on the protective bag
- Position the removed tow hitch and bag in the storage box. The ball must be pointing forwards to the right. Tighten in position using the strap.

26B

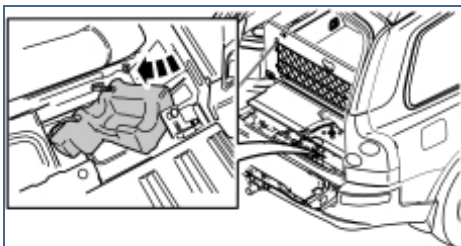

R8903856

26C



R8903857

27A



R8903860

## Storing the tow hitch

Applies to cars with two rows of seats

### Illustration A

- Remove the storage box and the strap from the kit. Thread the strap through the holes in the storage box. See the illustration.

### Illustration B

- Insert the storage box in the space to the right of the battery. Press the box into place against the floor. Be careful with the storage box. It is made of Frigolite which is brittle.



27B

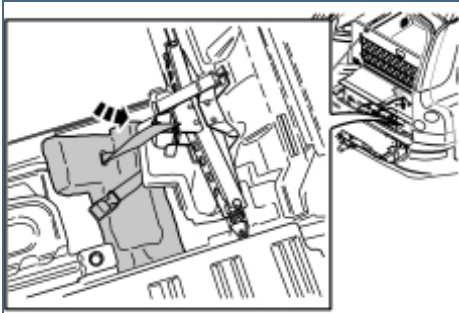

R8903861

## Illustration C

- Thread the supplied protective bag over the towing ball before removing the tow hitch
- Remove the tow hitch. Pull the string tight on the protective bag
- Position the removed tow hitch and bag in the storage box. The ball must be pointing forwards to the right. Tighten in position using the strap.

27C

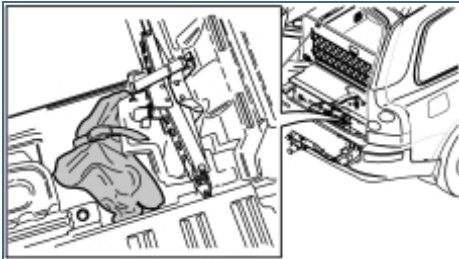

R8903862

## Finishing work

28A

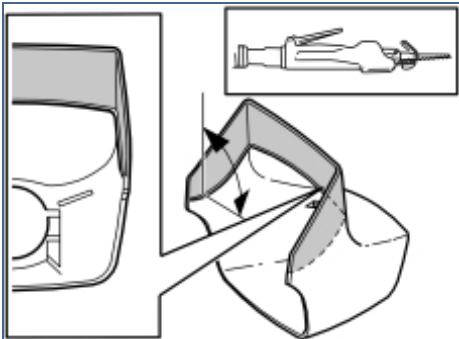

R8902736

## Illustration A

### Applies to cars with a rear skid plate

- Saw or cut along the top of the markings on the inside of the cover as illustrated. Cut the material at right-angles. After cutting, smooth off the edges using a file.

## Illustration B

### Applies to all models

- Install the cover on the connection stud. Press so that the cover is secure.

### Caution!

Do not use the cover as a step. There is a risk of personal injury by standing on the cover.

28B

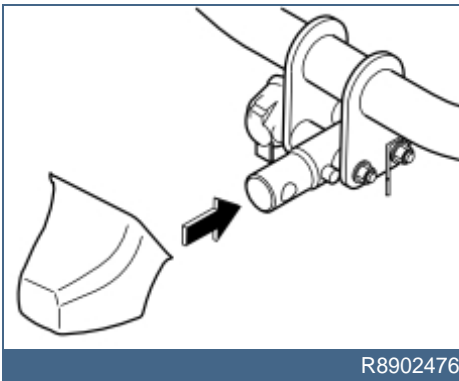

R8902476

29

## Finishing work

- Reinstall the protective cover and holder for the battery
- Reinstall the spare wheel.





#### **Applies to cars with accessory electronic modules (AEM)**

- Reinstall the bracket with the accessory electronic module (AEM). Connect the connectors if disconnected.

#### **Applies to all models**

- Reinstall the panels, storage boxes and floor hatches
- Tighten the screws in the load securing eyelets. Tighten to **24 Nm (18 lbf.ft.)**.

30

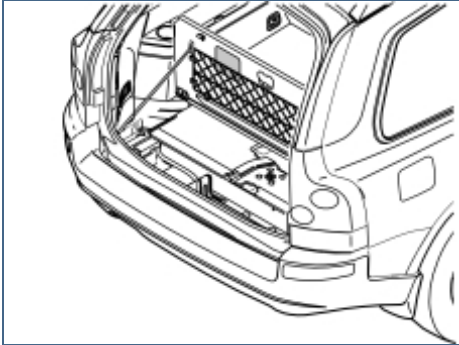

R8902389

#### **Finishing work**

- Apply the decal supplied to the underside of the rear floor hatch as illustrated.