

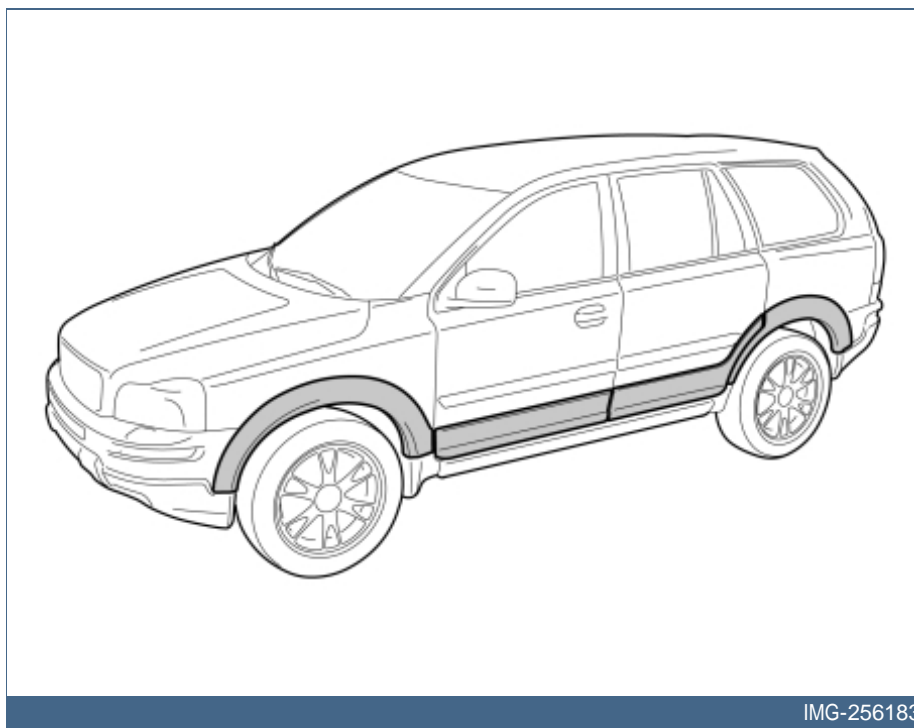

XC90

Section	Group	Weight(Kg/Pounds)	Year	Month
8	863	9/19.8	2007	04



Installation instructions, accessories - Body kit

Volvo Car Corporation Göteborg, Sweden



Required tools



A0000162



A0000163



IMG-239940



R0801744



A0000177



A0000214

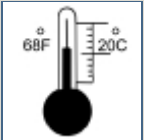

M0000232

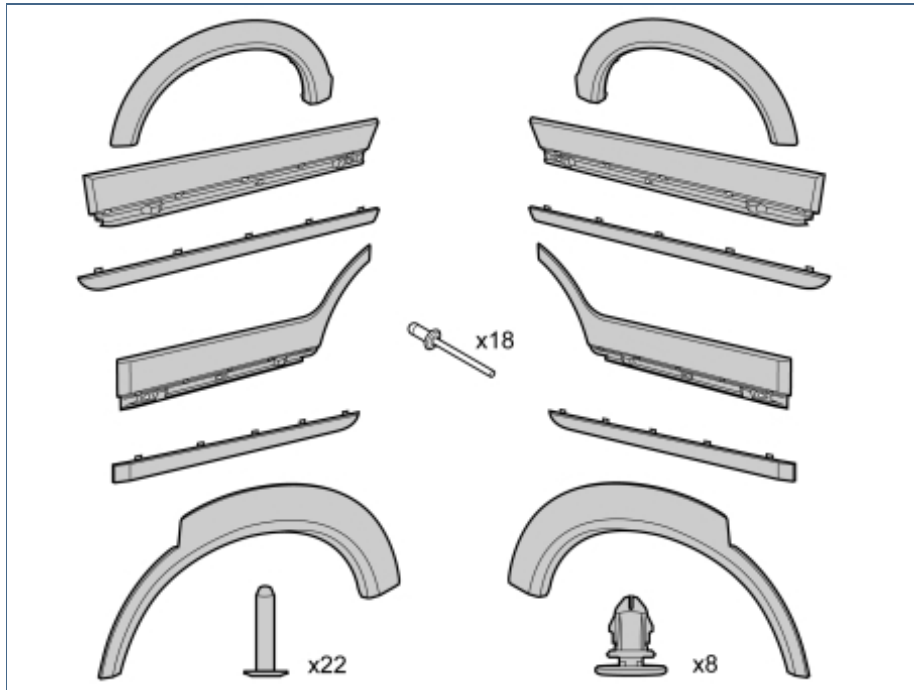

IMG-256184

Any comments on this publication? Please contact your nearest retailer. Thank You!

Publ.no:	Issue:	Kit no:
Comments:.....		
.....		
.....		
.....		

From:	
Address:	
Telephone:	
Telefax:	

IMG-213320





INTRODUCTION

- **NOTE! Read through the entire text before carrying out any work.**
- The front page gives the date of this edition and the edition it replaces
- The second page shows the tools needed for the installation and the contents of the installation kit
- The illustrations display the procedure in order of operation. The order of operation is repeated in the text section
- Cut out the text page in order to follow the illustrations and text at the same time.

Body kit

Note!

Accessories such as parking assistance, front/rear and tow bars should be installed on the car before the body kit.



1

- Wash and degrease the car.

Note!

It is important that the surfaces on which the side panels will be mounted are completely free of tar and other road dirt.

2A

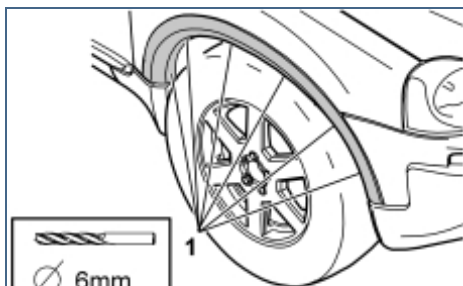

R8601000

Removing the front wheel arch extensions

Illustration A

- Drill out the five pop rivets (1) holding the front fender widener to the edge of the wheel arch. Use a $\varnothing 6\text{ mm}$ " (1/4") diameter drill bit.
- Remove the rivet swarf and ensure that none remains in the holes.

Illustration B

- Carefully pry off the front lower edge of the wheel arch extension. Use a plastic weatherstrip tool.

Note!

Do not damage the paint work.

- Fold out the front lower edge of the wheel arch extension to expose the first mounting clip
- Insert the weatherstrip tool at the side of the clip, between the panel and the wheel arch extension. Twist the weatherstrip tool to pull the clip away from the edge of the wheel arch or so that it breaks.
- Then continue in the same way until all five clips have released.
- Remove the wing extension. Place the wing extension to one side. This will not be reused.

2B

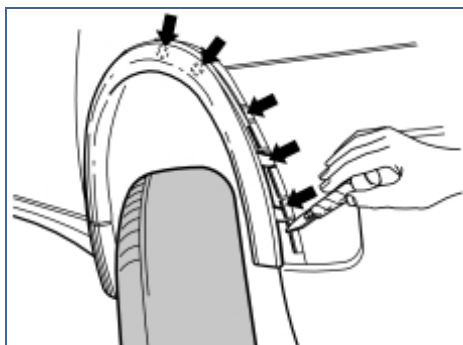

R8600937

3

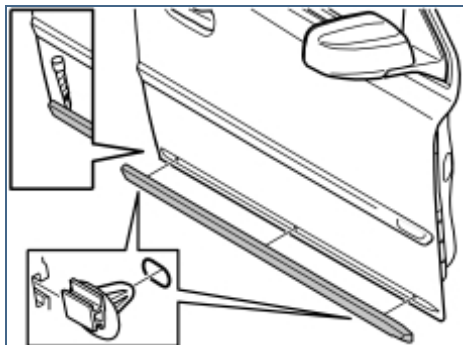

R8400929

Removal of the lower trim strip on the front and rear doors.

- Use the weatherstrip tool to pry the rear edge of the trim strip until the tape comes away at the bottom and top edges.

Note!

Do not damage the paint work.

- Push the trim strip to one side to expose the first clip
- Remove the clip in the same way as for the clips on the wheel arch extension
- Pry the trim strip off working forwards. Remove the last clip in the same way as



previously

- Place the trim strip to one side. This will not be reused.

4A

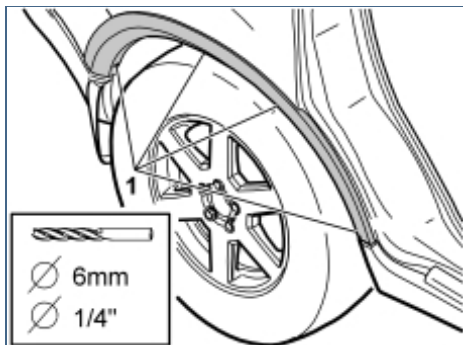

R8600978

Removing the rear wheel arch extensions

Illustration A

- Drill out the four pop rivets (1) holding the fender widener to the edge of the wheel arch. Use a $\varnothing 6\text{ mm}$ " (1/4") diameter drill bit.
- Remove the rivet swarf and ensure that none remains in the holes.

Illustration B

- Carefully pry off the front lower edge of the wheel arch extension. Use a plastic weatherstrip tool.

Note!

Do not damage the paint work.

- Fold out the front lower edge of the wheel arch extension to expose the first mounting clip
- Insert the weatherstrip tool at the side of the clip, between the panel and the wheel arch extension. Twist the weatherstrip tool to pull the clip away from the edge of the wheel arch or so that it breaks.
- Then continue in the same way until all six clips have released.
- Pull the two mounting hooks at the rear edge of the wheel arch extension off from their mountings.
- Remove the wing extension. Place the wing extension to one side. This will not be reused.

4B

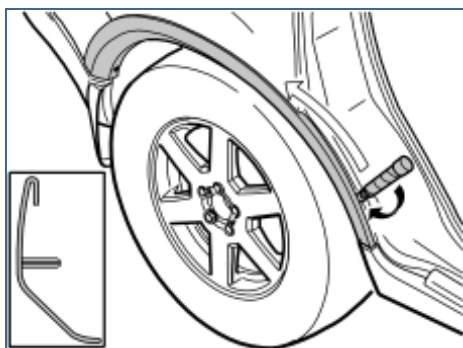

R8600979

5

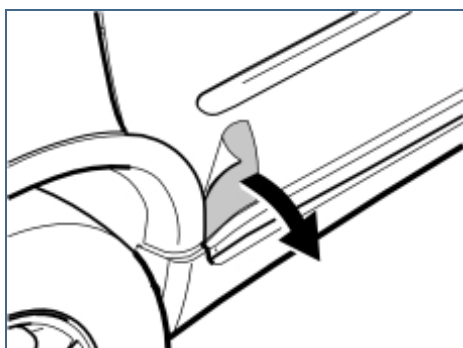

R8601039

Removing stone-chip protection

- Remove the stone-chip protection at the rear edge of the rear door.



6

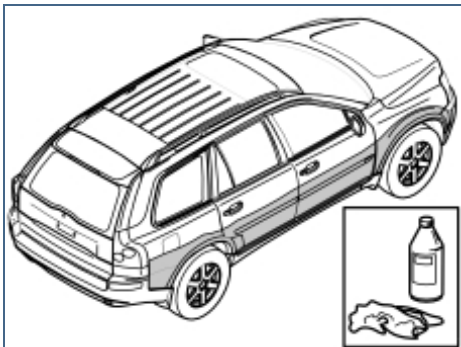

R8504390

Cleaning panel surfaces

- Wash the entire surface of where the new decor panels and fender wideners shall be installed. Use cleaner H **part no.1161436**.
- Wipe dry.

7

Marking the primer surface on the bodywork

Note!

Two people must help each other to mark the primer surface on the bodywork.

- Remove the side panel components from the packaging
- Check how the mounting tape is positioned on the components. This determines where the primer must be applied and where the markings must be made
- Clean the protective film with a moist cloth. Use a mixture of 30% windshield washer fluid and 70% water.

Note!

There must not be any dirt or grease on the protective film on the panel. This could contaminate the bodywork when making markings in the next step.

- Wipe dry.

8

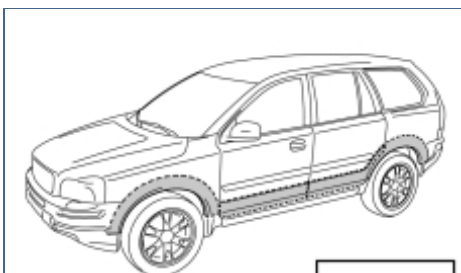

IMG-256204

Marking the panels' outer contours

- Check-fit the panels, according to steps 11-15, and mark these outer contours with a Whiteboard pen.

Note!

Leave the mounting tape's protective film in place and make sure that the panels are aligned horizontally.

- Install clips on side panel (door) 8 pcs.

9

Applying primer to the bodywork

- Take the primer **part no. 1161727** and cotton buds from the kit.

Note!

The primer must be applied to the whole car in one operation. Any spillage must be wiped up immediately.



- Apply primer inside the panels' outer contours.

Note!

It is important that nothing ends up outside the markings, especially by the panels' top sides where there shall be a gap of approx. 1 mm between the primer and the marking.

- Allow the primer to harden for 15 minutes.

Caution!

The side panels shall be installed at the earliest 15 minutes, and at the latest 3 hours, after applying the primer.

10

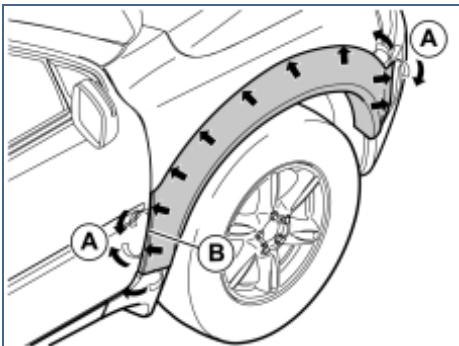

IMG-256205

Fastening side panel, front fender

- Fold up the protective film on the sides of the panel (A).

Note!

Be careful so that the protective film does not come off on the back of the panel.

- Make sure that the measurement **2mm (5/64")** between trailing edge fender widener and the front fender's trailing edge is obtained (B).
- Press the panel into place against the front fender at every point that there is tape.
- Apply a pressure of **1-2 kg/cm² (14-28 lbf/in²)** around the entire panel so that the tape sticks firmly.

11

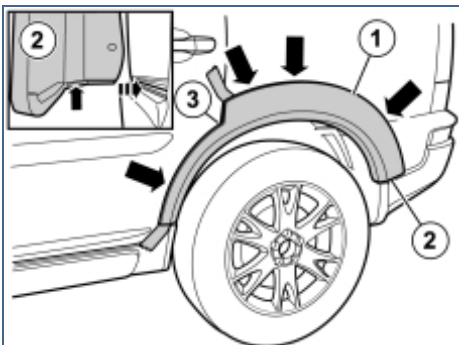

IMG-256206

Fastening side panel, rear fender

- Open the back door.
- Bend in the panel against the rear fender while making sure that the side panel's guide pin fits in the corresponding hole in the edge of the wheel arch (1).
- Place the raised edge (guide edge) on the fender widener butt-to-butt with bumper as shown (2).
- Place the corner in the door opening (3).

Note!

Make sure that the panel does not touch the back door.

- Fold up the protective film on the sides and the lower edge of the panel.



Note!

Be careful so that the protective film does not come off on the back of the panel.

- Press the panel into place against the rear fender at every point that there is tape.
- Apply a pressure of **1-2 kg/cm² (14-28 lbf/in²)** around the entire panel so that the tape sticks firmly.

12

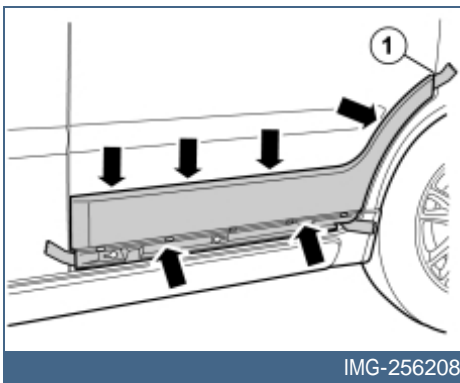

Fastening side panel, back door

- Fold up the protective film over the edge of the panel.
- Remove the lower protective film on the side panel.
- Fold in the panel with the lower edge first and carefully insert the panel's guide pin as well as click in the two clips in the door side's hole without fastening the tape on the panel's corners.
- Move the panel as close as possible to the door side without the tape in the corners fastening.
- Make sure that the panel's rear upper corner (1) follows the same line as the rear fender's side panel (there is some clearance between the guide pins and the holes in the door side).
- Press the panel into place at the upper corners and carefully remove the upper protective film by pulling it off from both ends at the same time.

Note!

Make sure that the protective film does not come off on the back of the panel. The panel may have contact with the side of the door with some pressure.

- Press the upper section of the panel into place against the side of the door. Press the panel so that it is firmly secured.
- Apply a pressure of **1-2 kg/cm² (14-28 lbf/in²)** around the entire panel so that the tape sticks firmly.

13

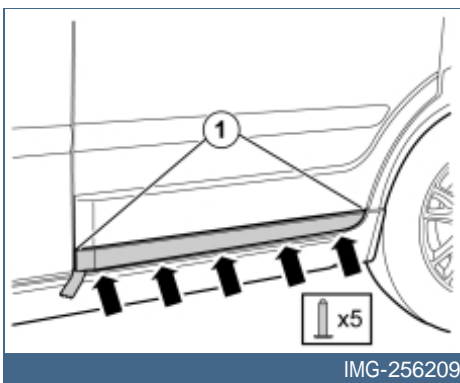

Fastening decor strip, back door

- Remove the protective film on the strip and move it in to correct position on the side panel.
- Make sure that the line between the decor strip and panel is obtained by pressing up the upper corners on the strip (1).
- Apply a pressure of **1-2 kg/cm² (14-28 lbf/in²)** around the entire panel so that the tape sticks firmly.
- Press in the 5 clips in the lower edge on the side panel.



14

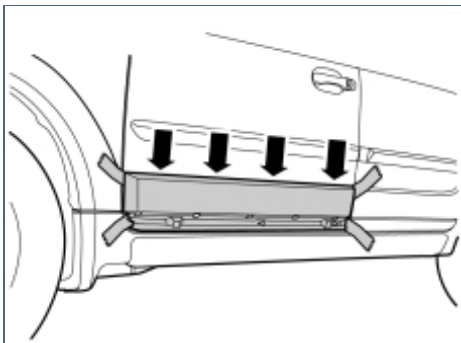

IMG-256210

Fastening side panel, front door

- Fold up the protective film on the panel's upper edge.
- Loosen the lower protective film on the side panel.
- Fold in the panel with the lower edge first, carefully insert the panel's guide pin as well as click in the two clips in the door side's hole without fastening the tape on the panel's corners.
- Make sure that the panel's rear/upper corner follows the same line as the back door's side panel (there is some clearance between the guide pins and the holes in the door side).
- Press the panel into place at the upper corners and carefully remove the upper protective film by pulling it off from both ends at the same time.

Note!

Make sure that the protective film does not come off on the back of the panel. The panel may have contact with the side of the door with some pressure.

- Press the upper part of the panel into place against the side of the door. Press the panel so that it is firmly secured.
- Apply a pressure of **1-2 kg/cm² (14-28 lbf/in²)** around the entire panel so that the tape sticks firmly.

15

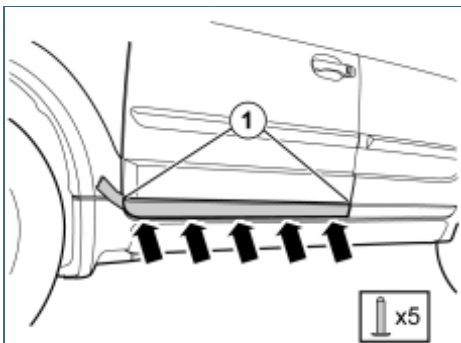

IMG-256211

Fastening decor strip, front door

- Remove the protective film on the strip and move it in to correct position on the side panel.
- Make sure that the line between the decor strip and panel is obtained by pressing up the upper corners on the strip (1).
- Apply a pressure of **1-2 kg/cm² (14-28 lbf/in²)** around the entire panel so that the tape sticks firmly.
- Press in the 5 clips in the lower edge on the side panel.



16

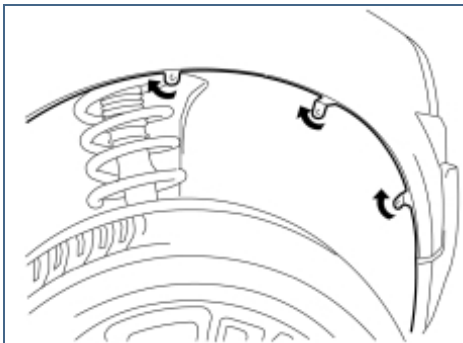

IMG-256212

- Fold in the mounting lugs on the front fender's side panel, so that the holes in these align with the holes in the fender liner.

17

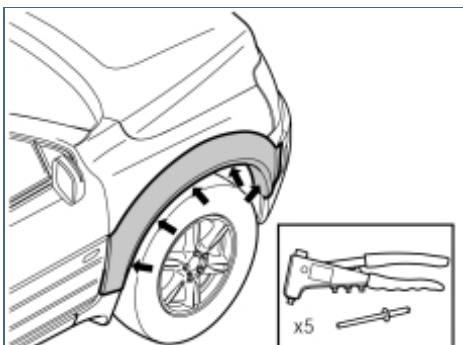

IMG-256213

- Pop rivet the fender widener's edges to the fender liners along the wheel arches in the front fender.

18

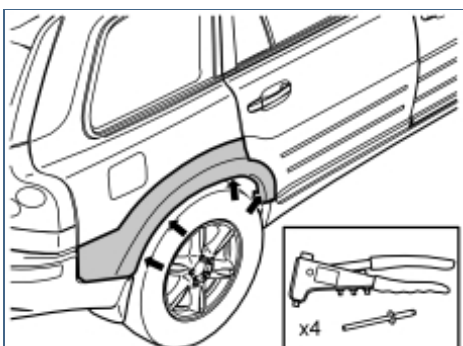

R8600994

- Pop rivet the fender widener's edges to the fender liners along the wheel arches in the rear fender.

19

- Remove the whiteboard markings with a dry rag.
- The car must be kept dry and at a temperature of at least 15 C (59 F) for 2 hours
- Do not wash the car for 72 hours after installing the side panels.