

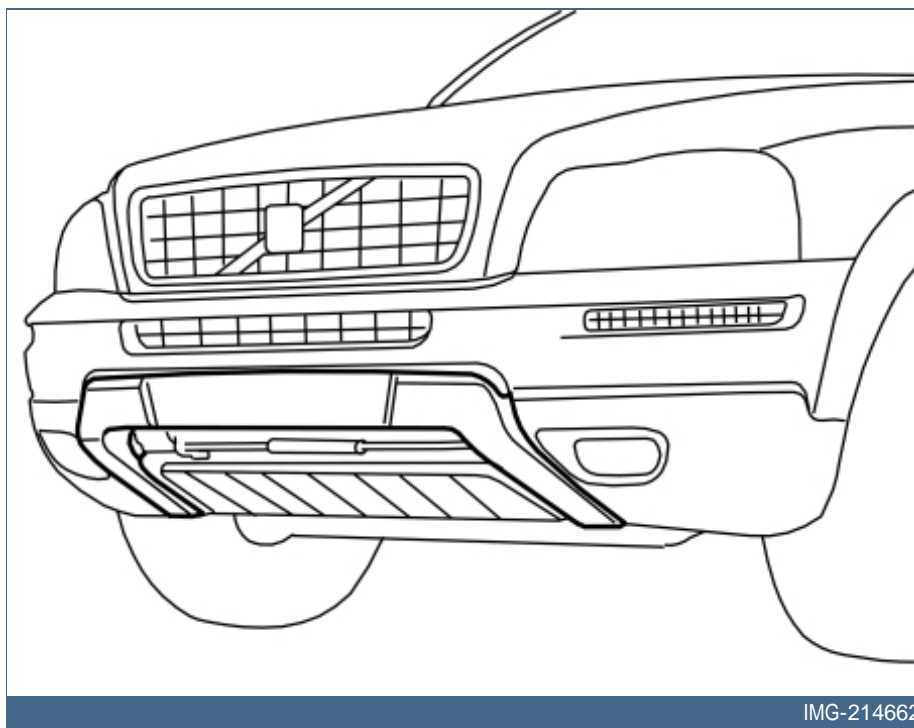

XC90

Section	Group	Weight(Kg/Pounds)	Year	Month
8	86	N/A	2005	11





## Required tools

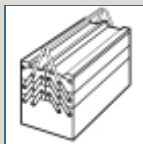

A0000162

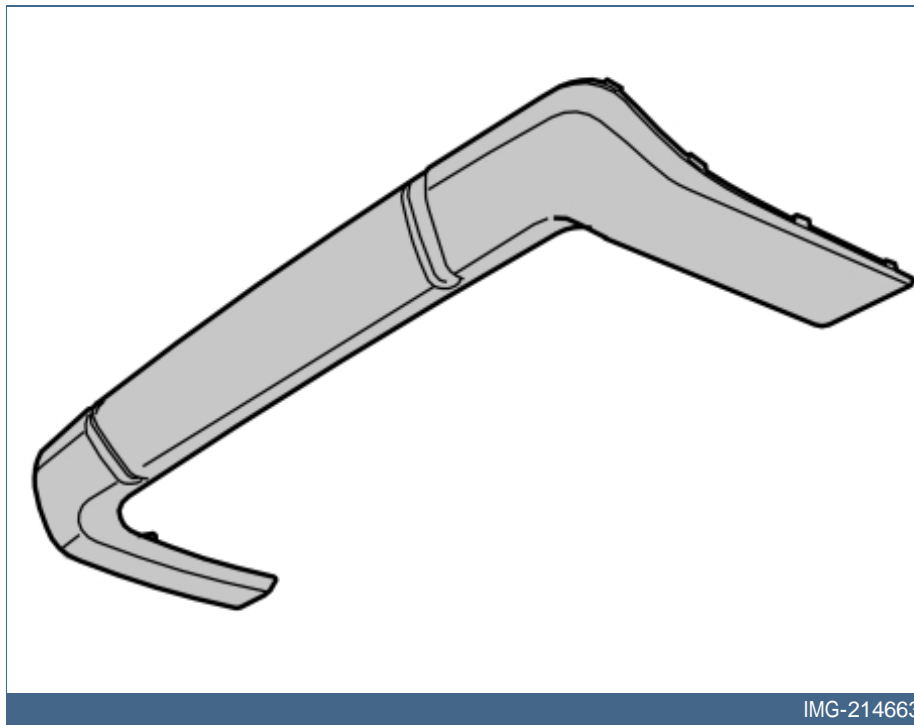

IMG-214663

Any comments on this publication? Please contact your nearest retailer. Thank You!

Publ.no:	Issue:	Kit no:
Comments:.....		
.....		
.....		
.....		

From:	
Address:	
Telephone:	
Telefax:	

IMG-213320





## INTRODUCTION

- **NOTE! Read through the entire text before carrying out any work.**
- The front page gives the date of this edition and the edition it replaces
- The second page shows the tools needed for the installation and the contents of the installation kit
- The illustrations display the procedure in order of operation. The order of operation is repeated in the text section
- Cut out the text page in order to follow the illustrations and text at the same time.

## Front bumpers

### Note!

Applies to trim panels that are only primed. Painting must be carried out in accordance with the Service Manual "Touch up spraying" section 8 (80). Note that the trim panel must be cleaned, ground and then cleaned again before painting in accordance with the instructions in the Service Manual.

### Caution!

The trim panel is manufactured of a PUR plastic which is very malleable. If the plastic part is not adequately supported in storage or when mounted during painting then there is significant risk that the plastic will change shape. Guide pins or other protruding parts must not bear the weight of a plastic part. Lay the plastic parts with support across a wide area. The malleability will be even greater when heated. Drying in an oven must not be used in temperatures above 50 C. The best method is to allow the plastic parts to dry in the air.



1

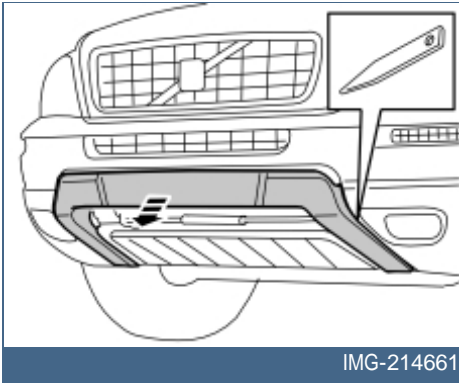

IMG-214661

- Detach the existing bumper by carefully prizing at the lower edge, between bumper and bumper cover, using a plastic weatherstrip tool. Following which, pull the bumper straight out so that the catches release.

2

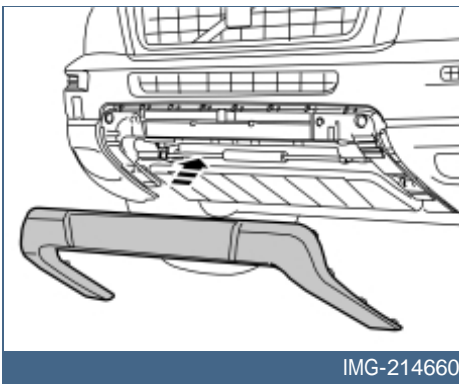

IMG-214660

- Align the new bumper from the kit and press it in.

**Note!**

Make sure that all of the catches engage.