

# Installation instructions, accessories - Rear skid plate

Volvo Car Corporation Göteborg, Sweden



## XC90

Section	Group	Weight(Kg/Pounds)	Year	Month
8	86	0.35 / 0.77	2005	04

XC90 2003, XC90 2003, XC90 2004, XC90 2004, XC90 2005, XC90 2005, XC90 2006, XC90 2006, XC90 2007, XC90 2008

Replaces issue: 2002 03

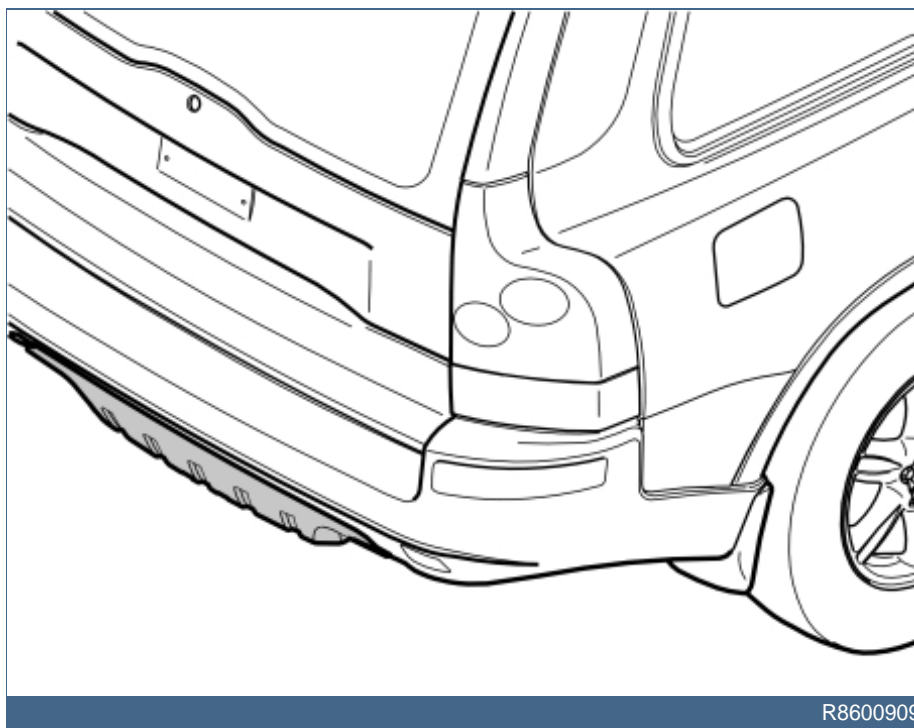

R8600909

# Installation instructions, accessories - Rear skid plate

Volvo Car Corporation Göteborg, Sweden



## Required tools



A0000162



A0000163



Nm  
lbf.ft

A0000161

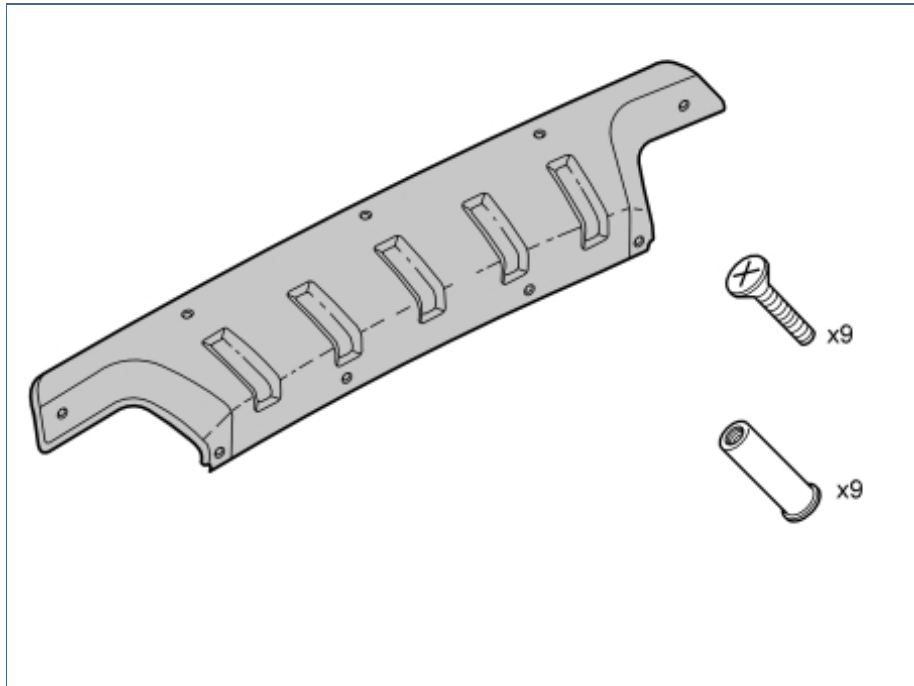

R8600923

Any comments on this publication? Please contact your nearest retailer. Thank You!

Publ.no:	Issue:	Kit no:
Comments:.....		
.....		
.....		
.....		

From:	
Address:	
Telephone:	
Telefax:	

IMG-213320

# Installation instructions, accessories - Rear skid plate

Volvo Car Corporation Göteborg, Sweden





## INTRODUCTION

## Rear skid plate

- **NOTE! Read through the entire text before carrying out any work.**
- The front page gives the date of this edition and the edition it replaces
- The second page shows the tools needed for the installation and the contents of the installation kit
- The illustrations display the procedure in order of operation. The order of operation is repeated in the text section
- Cut out the text page in order to follow the illustrations and text at the same time.



1

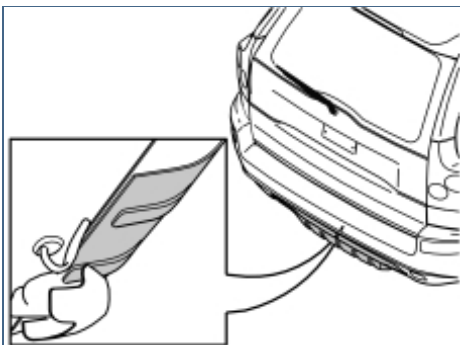

R8600924

**Applies to cars with detachable towbars (EU/AUS)**

- Remove the cover from the towbar.

2

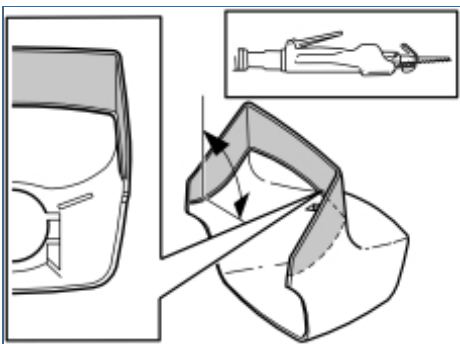

R8902736

**Applies to cars with older model detachable towbars (EU/AUS)**

- Cut out the cover following the markings on the inside
- Even off the edges using a file.

3A

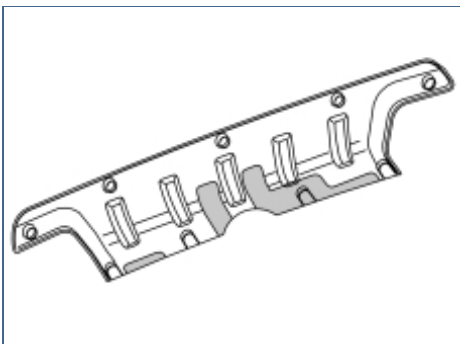

R8600977

**Illustration A  
Illustration B**

**Applies to all cars with towbars**

- Cut out the notch in the skid plate following the markings on the inside
- Even off the edges using a file.

Illustration B is for cars with newer model detachable towbars EU, P/N.30744116 (see type plate on towbar).

3B

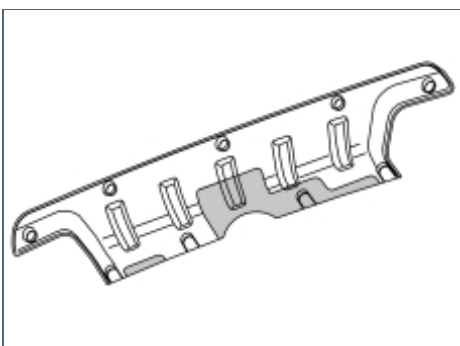

IMG-222760



4

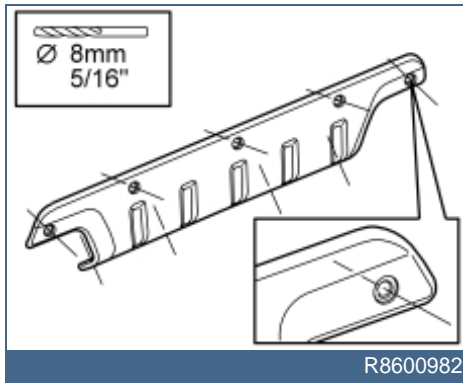

**Applies to all models**

- Drill out the nine countersink markings in the skid plate. Use an **Ø 8 mm (5/16")** diameter drill bit. Drill in the centre of the countersinks.
- If necessary, even off the edges using a small round file.

5

**Applies to all models**

- Clean the section of the bumper surface that will be covered by the skid plate.

6A

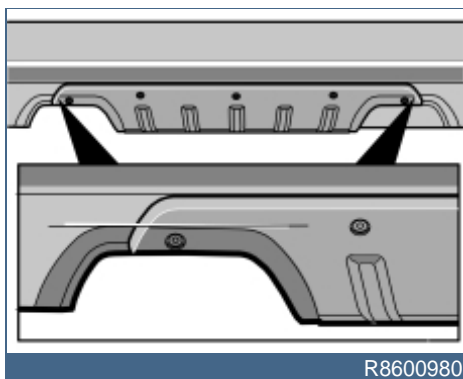

**Illustration A**

**Note!**

Two people are required for this operation.

- Align the skid plate at the sides by holding it in position so that it is aligned with the embossing at the exhaust pipe. If the car has a towbar, the skid plate must be aligned symmetrically with the vertical mounting brackets for the towbar.
- Align the skid plate vertically so that the embossing is at the same level as the embossing on the bumper seen from immediately behind.

6B

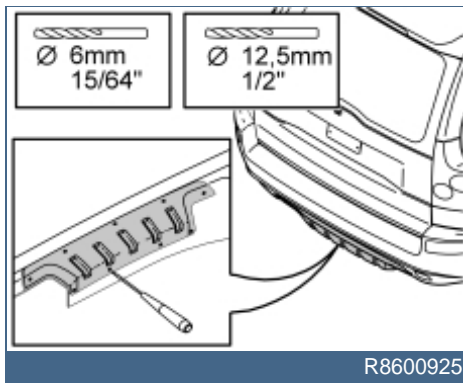

**Illustration B**

- Accurately mark the holes for the screws by pressing through the holes in the skid plate using a pointed tool
- Remove the skid plate. First drill out the holes. Use a **Ø 6 mm (15/64 ")** diameter drill bit. Then enlarge the holes using a **Ø 12.5 mm (1/2")** diameter drill bit. Drill at right angles to the underlying surface. Do not enlarge the holes excessively or the rubber nut may not secure.
- Remove any swarf. Clean around the edges of the holes.

7A

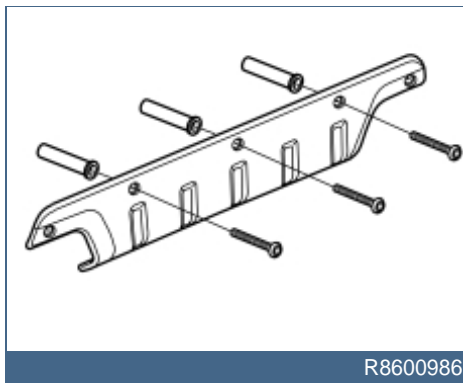

**Illustration A**

- Take three screws and thread them through the three upper / middle holes in the skid plate. Take three rubber nuts and screw them 2–3 turns on to the three screws. The rubber nuts must be turned so that the threaded ends enter into the holes in the bumper during installation.

**Illustration B**

- Press the other rubber nuts into place in the drilled holes in the bumper, with the threaded ends first



7B

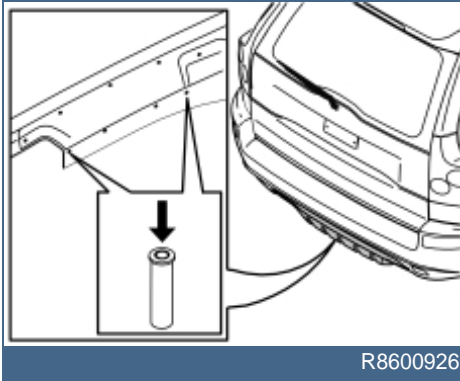

- Press the skid plate all the way into place in the three upper / centre holes in the bumper
- Screw in the other screws as far as they will go
- Tighten the skid plate with the screws. Tighten to **1.5-2 Nm (1-1.5 lbf.ft.)**.

8

**Applies to cars with detachable towbars (EU/AUS)**

- Reinstall the cover on the towbar.