



XC90

Section	Group	Weight(Kg/Pounds)	Year	Month
8	86		2004	08

XC90 2003, XC90 2004, XC90 2005, XC90 2006, XC90 2007, XC90 2008, XC90 2009

Installation instructions, accessories - Wheel arch extensions

Volvo Car Corporation Göteborg, Sweden



Required tools



A0000162



A0000163



A0000214



A0000177

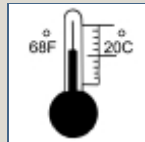

M0000232



A0000172

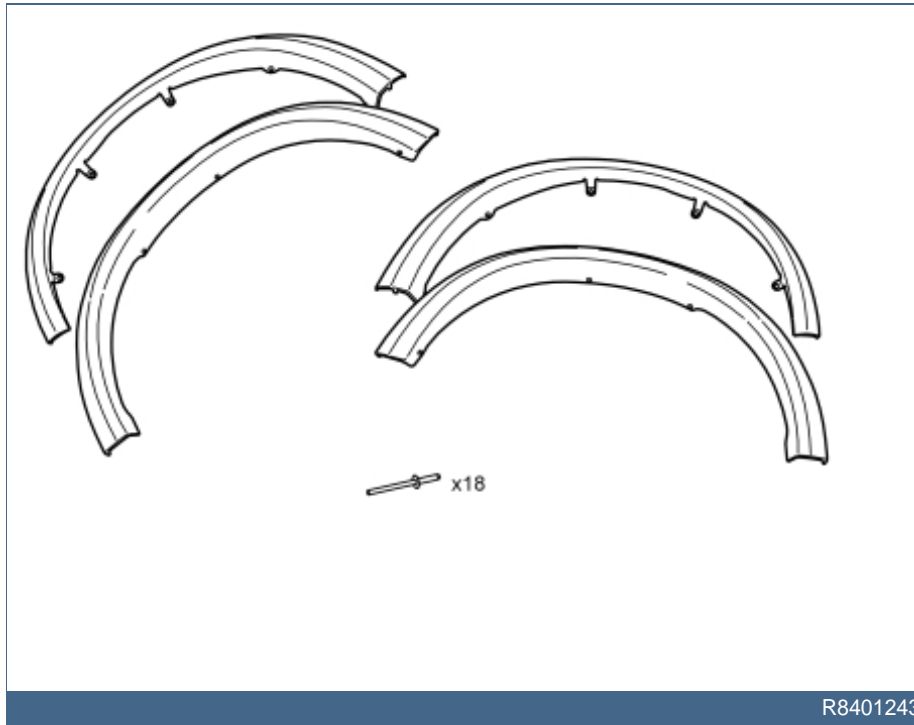

Any comments on this publication? Please contact your nearest dealer. Thank you!

Publication no: MA30660629, Issue: 2004-08
Comments:.....
From:.....
Address:.....
Telephone no:.....
Telefax:.....





INTRODUCTION

Wheel arch extensions

- **NOTE! Read through the entire text before carrying out any work.**
- The front page gives the date of this edition and the edition it replaces
- The second page shows the tools needed for the installation and the contents of the installation kit
- The illustrations display the procedure in order of operation. The order of operation is repeated in the text section
- Cut out the text page in order to follow the illustrations and text at the same time.



1

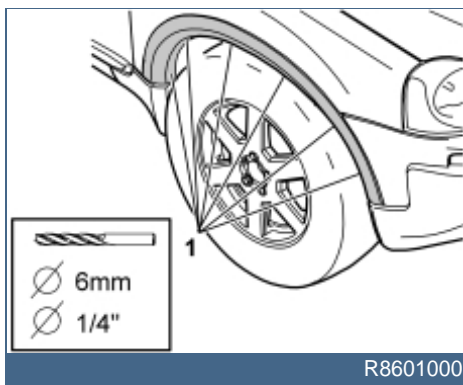

Removal

Removing the front wheel arch extensions

- The front wheel arch extensions are secured with three catches in the lower edge, tape in the top edge, five clips and six pop rivets.

Drill out the six pop rivets (1) holding the front wheel arch extension to the edge of the wheel arch. Use a **Ø6 mm (1/4")** diameter drill bit.

- Remove the remains of the rivets.

2

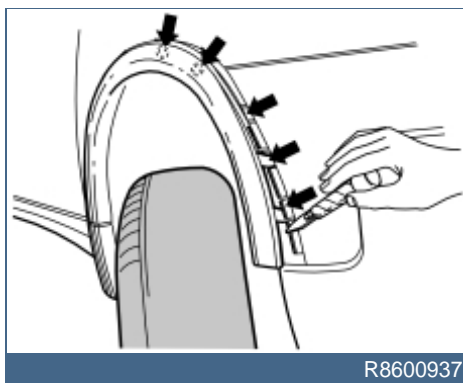

Removal

- Carefully pry off the front lower edge of the wheel arch extension. Use a plastic weatherstrip tool.

Note!

Do not damage the paint work.

- Fold out the front lower edge of the wheel arch extension to expose the first mounting clip.
- Insert the weatherstrip tool at the side of the clip, between the panel and the wheel arch extension. Twist the weatherstrip tool to pull the clip away from the edge of the wheel arch or so that it breaks.
- Then continue in the same way until all five clips have released.
- Remove the wing extension. Place the wing extension to one side. This will not be reused.

3

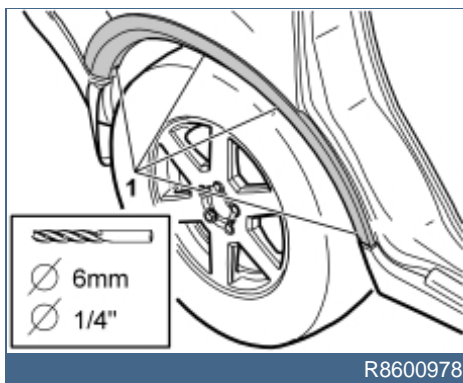

Removal

Removing the rear wheel arch extensions

- The rear wheel arch extensions are secured with two catches in the rear lower edge, tape in the top edge, six clips and four pop rivets.

Drill out the four pop rivets (1) holding the wheel arch extension to the edge of the wheel arch. Use a **Ø6 mm (1/4")** diameter drill bit.

- Remove the remains of the rivets.



4

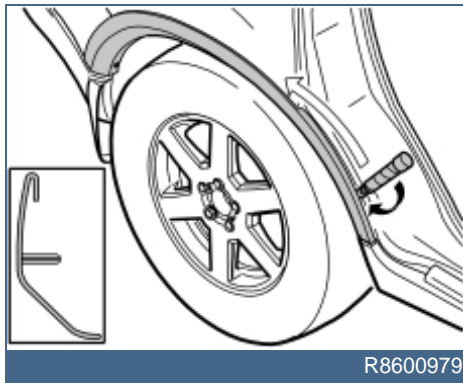

Removal

- Carefully pry off the front lower edge of the wheel arch extension. Use a plastic weatherstrip tool.

Note!

Do not damage the paint work.

- Fold out the front lower edge of the wheel arch extension to expose the first mounting clip.
- Insert the weatherstrip tool at the side of the clip, between the panel and the wheel arch extension. Twist the weatherstrip tool to pull the clip away from the edge of the wheel arch or so that it breaks.
- Then continue in the same way until all six clips have released.
- Pull the two mounting hooks at the rear edge of the wheel arch extension off from their mountings.
- Remove the wing extension. Place the wing extension to one side. This will not be reused.

5

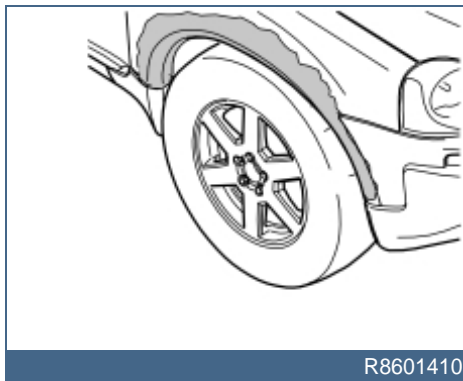

Removal

- Clean the marked surface around the edge of the wheel arch where the tape shall be affixed using isopropanol P/N 1161721. Wipe dry.
- Clean the corresponding surface on the edge of the wheel arch for the rear wheel.
- Repeat steps 1-5 for the other side.

6

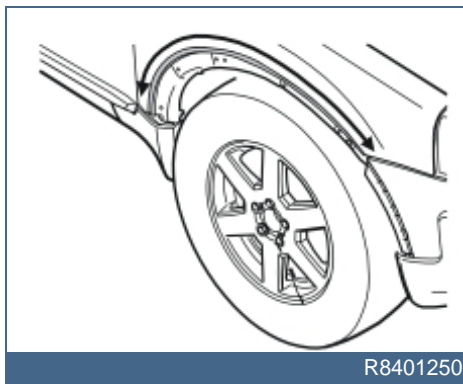

Installation

Applying the primer to the body

Caution!

The wheel arch extensions can be installed at the earliest 15 minutes or at the latest 3 hours after application.

- Take the primer (P/N 1161727) and cotton buds from the kit.

Note!

The primer must be applied to the car in one operation, and any spillage must be wiped up immediately.

- Apply primer to the surfaces where the tape shall adhere. Make sure that there is no primer outside of the surfaces to which the tape shall adhere.
- Allow the primer to harden for 15 minutes.



7

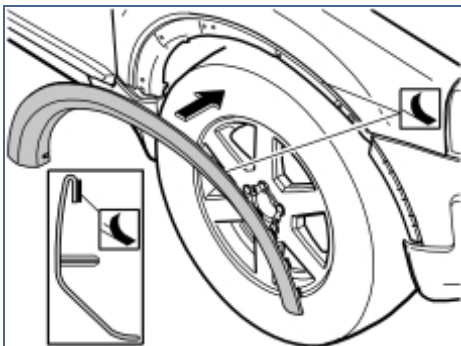

R8401244

Installation

- Detach the backing from the mounting tape at the ends of the new wheel arch extension to the front wing in order to facilitate removal when the wheel arch extension is installed.
- Insert the wheel arch extension guide pins in the corresponding holes around the edge of the wheel arch.

8

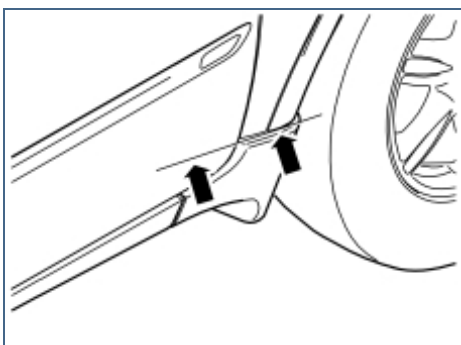

R8401245

Installation

- Check that the lower edge of the front wing's rear edge is level with the corresponding edge of the wheel arch extension.

9

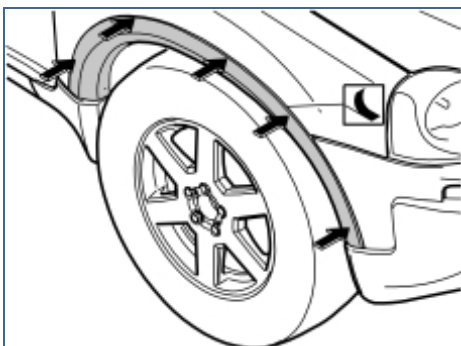

R8401246

Installation

- Press in the ends of the wheel arch extension where the tape was detached.
- Remove the remainder of the backing and press in the wheel arch extension so that the tape is firmly applied. At the same time make sure that the upper edge of the wheel arch extension follows the edge of the wing.

10

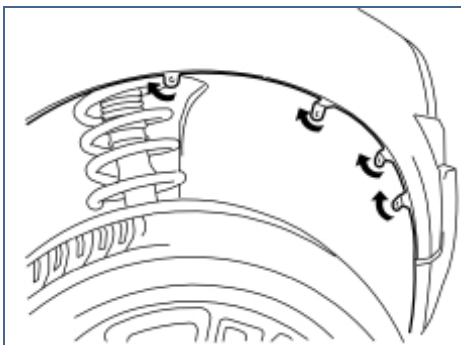

R8601028

Installation

- Fold in the mounting lugs on the front wing's wheel arch extension so that the holes in the mounting lugs align with the holes in the wing liner.



11

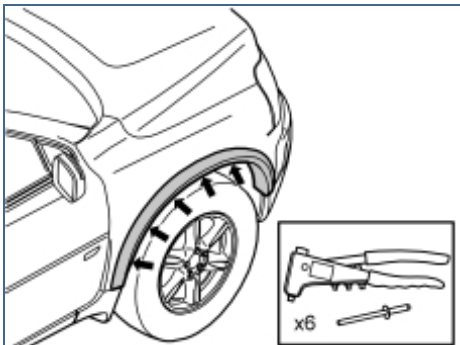

R8401247

Installation

- Take five pop rivets from the kit and securely rivet the wheel arch extension with the wing liner to the edge of the wheel arch.

12

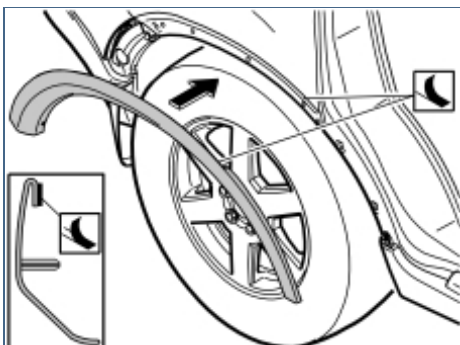

R8401248

Installation

- Detach the backing from the mounting tape at the ends of the wheel arch extension to the rear wing in order to facilitate removal when the wheel arch extension is installed.

13

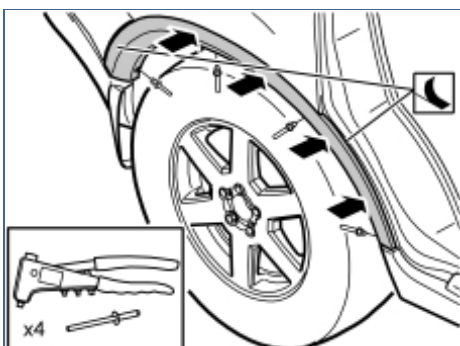

R8401249

Installation

- Press in the ends of the wheel arch extension where the tape was detached.
- Remove the remainder of the backing and press in the wheel arch extension so that the tape is firmly applied. At the same time make sure that the upper edge of the wheel arch extension follows the edge of the wing.
- Take four pop rivets from the kit and securely rivet the wheel arch extension to the edge of the wheel arch.
- Repeat steps 6-13 for the other side.

Note!

Keep the car indoors for 2 hours after the work has been completed and do not wash the car for 48 hours.